

# IMPORTANT!

If “clocking” of the starter block is required,  
it is critical that the infi-CLOCK ring be tightened correctly.

Note: The starter comes pre-clocked for most applications.



### Clocking steps:

1. Loosen the two bolts that retain the infi-CLOCK ring using a **T25 TORX bit**.   
**DO NOT USE A HEX KEY.**
2. Temporarily mount the starter to the engine.
3. Rotate the starter body to the preferred position and make a reference mark from the starter block to the starter body.
4. Remove the starter.
5. Rotate the block into position and tighten the two ring bolts. The bolts must be tightened evenly. While holding the ring parallel to the block, lightly snug each bolt. Evenly tighten the bolts in an alternating pattern. Torque to 50 in/lbs. Inspect the ring again to be certain it is parallel to the block.
6. Reinstall the starter to the engine.

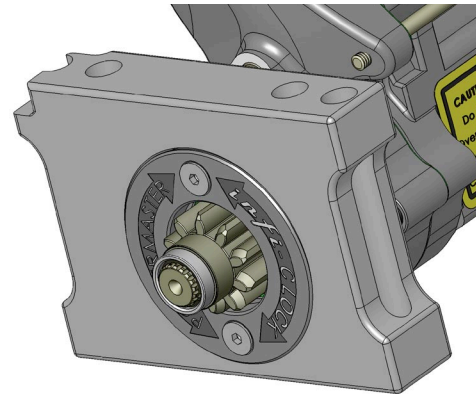

**Using Blue Loctite® or equivalent thread lock on the two ring bolts is REQUIRED!**

**\*Ring and block face must be parallel after clocking is complete.**

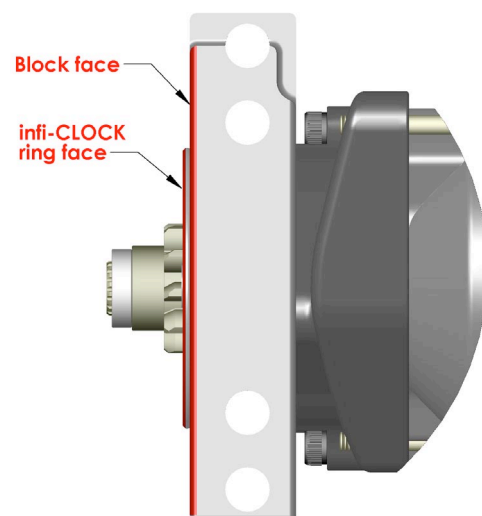

**See Reverse side for Shimming Instructions**



# IMPORTANT!

It is critical that the infi-CLOCK ring be tightened correctly.



After the starter has been installed, there should be 1/16" (0.062) minimum between the engine side of the ring gear and the front edge of the teeth on the starter pinion gear. Check this distance with the ring gear in at least three different positions. If the distance is too little, a shim can be installed inside the starter, which will pull the pinion into the starter an additional 1/16" (0.062). This will result in additional clearance between the pinion and the ring gear.

1. Mark the starter body to starter block position so it can be correctly positioned during reassembly.
2. Remove the two bolts that retain the infi-CLOCK ring using a **T25 TORX bit** (figure 1). **DO NOT USE A HEX KEY.**
3. Remove the ring and block.
4. Install the shim and reassemble as shown (figure 2)
5. Rotate the block into position and tighten the two ring bolts. The bolts must be tightened evenly. While holding the ring parallel to the block, lightly snug each bolt (figure 3). Evenly tighten the bolts in an alternating pattern. Torque to 50 in/lbs. Inspect the ring again to be certain it is parallel to the block.
6. Reinstall the starter to the engine.

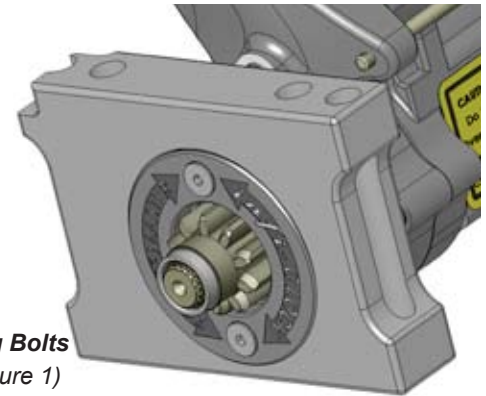

**Ring Bolts**  
(Figure 1)

**Using Blue Loctite® or equivalent thread lock on the two ring bolts is REQUIRED!**

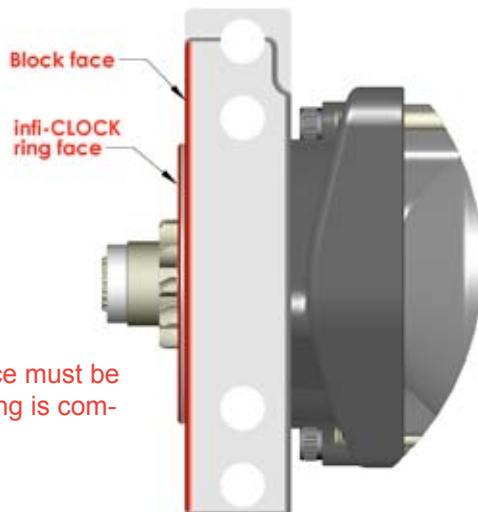

\*Ring and block face must be parallel after clocking is complete. (figure 3)

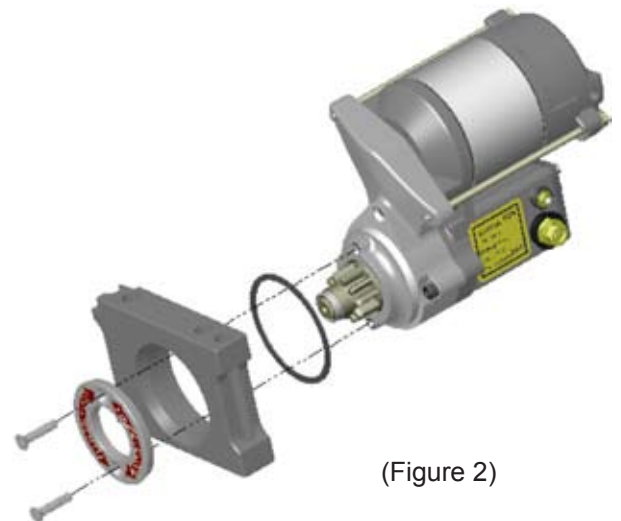

(Figure 2)

\*Powermaster recommends no more than one set of internal shims be installed in a starter.