

# DBK6466-4

## FORD FRONT 4 LUG

### DISC BRAKE CONVERSION KIT

FITS DRUM 6 CYL SPINDLES ONLY. DESIGNED FOR 4 LUG RIMS

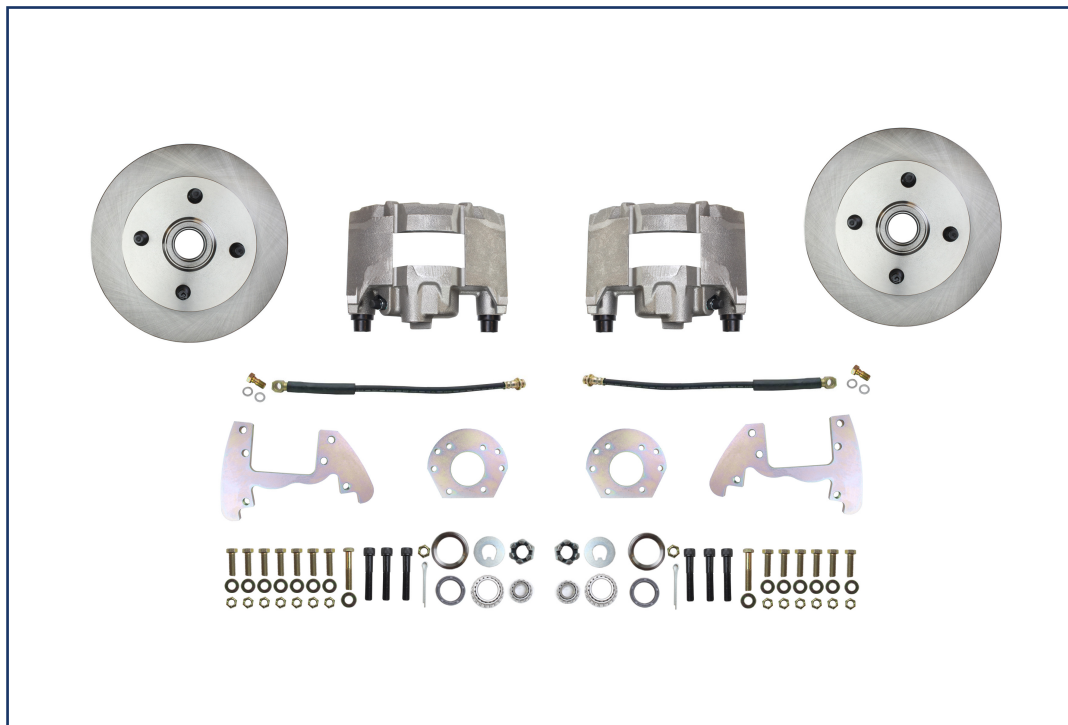

## INSTALLATION INSTRUCTIONS

FITS DRUM SPINDLES FROM 4 STUD CARS

**WARNING** Proper operation of your brakes is essential for your safety and the safety of others. Any brake service should be performed **ONLY** by persons experienced in the installation and proper operation of brake systems. It is the responsibility of the person installing any brake component or kit to determine the suitability of the component or kit for the particular application. After installation, and before operating your vehicle, be sure to test the function of the brakes under controlled conditions. **DO NOT DRIVE WITH UNTESTED BRAKES!**

**IMPORTANT** Take time to read all the literature that came with this kit. Before beginning installation check the provided list of parts against what you received to ensure that all parts are present. While this kit was designed to make the process of changing brake parts as simple as possible, **NOTE: WITH SOME KITS IT MAY BE NECESSARY TO MAKE MINOR CHANGES TO YOUR CAR! READ ALL WARRANTY DISCLAIMERS AND RETURN POLICIES INCLUDED IN THIS KIT PRIOR TO INSTALLATION!**

# INSTALLATION INSTRUCTIONS

<b>PARTS INCLUDED WITH THIS KIT:</b>	
<b>DESCRIPTION</b>	<b>QUANTITY</b>
Spindle Mounting Plates	2
Secondary Caliper Brackets	2
<b>Spindle bracket to spindle bolt set:</b>	
Long Bolts 2 x 3/8"-24 x 2 1/8"	2
Medium Bolts 6 x 3/8"-24 x 1.5"	6
Stover Lock Nuts 3/8"-24	6
Flat Washers 3/8"	16
<b>Spindle Bracket to caliper set:</b>	
Bolts 3/8"-16 x 1.25	8
Bolts 3/8"-16	8
Bolts 3/8"	8
<b>BRACKETS &amp; ROTOR COMPONENTS</b>	
<b>DESCRIPTION</b>	
Rotors	2
Brake Hoses	2
Caliper set (Pre Loaded w/ Pads)	1
Inner Bearing	2
Outer Bearing	2
Grease Seal	2
Dust Caps	2
Spindle Nut Washers & Castle Nuts	2
Cotter Pins	2

## PREPARING YOUR VEHICLE TO INSTALL YOUR BRAKE SYSTEM UPGRADE

1. Rack the vehicle.
2. If you don't have a rack, then you must take extra safety precautions.
3. Choose a firmly packed and level ground to jack up the vehicle.
4. Chock the rear wheels.
5. Jack the vehicle up and support it with jack stands and secure the pins.
6. Set the parking brake and put the transmission in park if automatic, reverse if manual transmission.
7. The front wheels should be allowed to free hang to relieve tension on the coil springs.

**IMPORTANT** NEVER rely on jacks to support a vehicle! Always test the steadiness of your stands that are supporting the vehicle before attempting to work on a raised vehicle!

## DISSASSEMBLE THE FRONT ROTORS:

1. Remove wheels and retain the lugs nuts for later use. Replace any that are damaged.
2. Remove the dust caps, the cotter pins, the nut cages, washers and spindle nuts, and attempt to remove the brake drum.
3. If the drum will not come off, remove the rubber cover from the backing plate and insert a narrow screwdriver or adjusting tool to relax the self-adjuster mechanisms. You may need to disengage the adjusting lever from the adjusting screw to be able to pull the brake drums over the shoes.
4. With the tool, retract the brake shoes so you can remove the brake drums, wheels bearings and grease seals.
5. Drain the brake fluid from the front circuit by loosening the wheel cylinder bleeder screws. Protect any painted surfaces with rags from brake fluid.
6. Carefully remove the metal brake lines from the rubber flex hoses and remove the hoses from their anchor mounts. Cover the ends of the brake lines with rags to protect painted surfaces.
7. Remove the brake shoes and the drum backing plates so all that remains are the factory drum spindles. For this kit, the factory spindles will be used so proceed to spindle preparation.

## COMPONENTS TO INSPECT, REPLACE OR UPGRADE DURING INSTALLATION OF DISC CONVERSION KITS

Tie rod ends and nuts	Adjustment sleeves	Control arm shafts, mounting bolts, & nuts
Control Arms	Idler arm and nut	Pitman Arm and nut
Upper Ball Joints and nuts	Lower Ball Joints and nuts	Shocks and hardware
Residual valves	Metering valves	Proportioning valves
Brake lines	Stainless steel brake lines	Stainless steel hardware

## SUGGESTIONS:

- » Take the time to identify any suspect parts that are not included in this kit.
- » Consider making upgrades such as converting to polyurethane bushings, performance shocks, tubular a-arms, etc.
- » Plan any Installation (s) of replacement parts during the various stages of the drum to disc conversion process.

## SPINDLE PREPARATION

1. To begin, you must have an original front drum spindle from a car equipped with an inline 6 cylinder.
2. On a level hard surface, jack up car up, and chock the rear wheels. Set emergency brake if so equipped.
3. Drain all brake fluid from the master cylinder.
4. **The single bowl master cylinder will need to be replaced with a dual reservoir master cylinder for disc/drum brakes and a matching proportioning valve is also needed.**
5. Remove the front wheels.
6. Disconnect the brake hoses from the hard lines on the frame.
7. Strip all of the drum brake components from the spindles.
8. Inspect the bearing landings and grease seal mounting surfaces.
9. Dress these surfaces with a wire brush, brake cleaner and sand paper as needed.
10. Repaint the spindles if desired.

## MOUNT THE CALIPER BRACKET

1. Locate the spindle mounting plate (has the large center hole) (**IMG 1**)
2. Locate the caliper mounting bracket (has threaded holes and 2 mounting ears) (**IMG. 2 & 3**)
3. Locate 8 of the 3/8"-16 x 1.25" COARSE thread bolts, 8 lock nuts and 8 washers.
4. The assembly for each side is made from 1 plate, 1 caliper bracket, 4 bolts, 4 washers and 4 nuts.
5. There will be a drivers' side and passenger's side version.
6. To make the two sides, make one set at a time.
7. Side 1: Place the spindle mounting plate on one side of the caliper mounting bracket.
8. Side 2: Place the spindle mounting plate on the opposite side of the caliper mounting bracket.
9. Using 6 of the 3/8"-16 (COARSE THREAD) bolts, washers and nuts as shown (**IMG 1-3 p.6-7**)
10. Bolt the spindle mounting plate and caliper mounting bracket together using the hardware from above.
11. Use the 2 & 1/8" bolts to bolt through the caliper bracket and steering arm where it is located on the casting. Shown in rear view (**IMG 2 p.6**)
12. Tighten all bolts.
13. At this point you should have 2 mirror image units.

## MOUNT THE ROTORS

1. Locate the inner and outer wheel bearings, grease seals, spindle nuts, washers, and cotter pins.
2. Separate into 2 matching piles used for each side.
3. **Locate the 2 spacer sleeve provided and slide on spindle shaft with the curved side facing inward. DO NOT SKIP THIS STEP!**
4. Test fit the bearings and mounting hardware onto each spindle.
5. Sand any burrs that prevent mounting them.
6. Liberally grease the larger inner bearing by hand or with a bearing packer.
7. Place it into the brake rotor.
8. Next place the grease seal there and drive it in evenly and carefully using a wood block or similar tool.
9. Coat the lip of the grease seal with bearing grease.
10. Then turn over the rotor and add more wheel bearing grease into the hub section of the rotor.
11. On the spindle, lightly coat the seal and bearing mounting surfaces with grease, so the new assembly slides on with ease.
12. Now grease the outer bearing and have it ready to install.
13. Place the rotor onto the spindle shaft and push the outer wheel bearing into position.

## **MOUNTING THE CALIPERS**

1. Pick up the brake calipers and make a note of where the brake bleeder screws are.
2. When the calipers are mounted, the bleeder screws must face up away from the ground.
3. Next remove the mounting bolts from the calipers.
4. Using caliper slide grease, coat the mounting bolts and the caliper slide sleeves.
5. Next remove the inner and outer brake pads.
6. Use disc brake quiet glue on the mounting surface of the pads.
7. Put disc brake quiet on the contact surfaces on the calipers, where the brake pads ride.
8. Let it get tacky and put the pads back into the caliper.
9. Now place the completed caliper into the caliper bracket over the rotor.
10. Install the 2 mounting bolts. Tighten these down 30-40 ft. lbs. **IMG. 4**
11. Test spin the rotor for clearance.
12. Now mount the new brake hoses with copper washers to the calipers using the supplied banjo bolts.
13. Attach them to the hard lines on the frame.
14. Turn the steering wheel from lock to lock to verify the brake hoses are placed correctly.
15. Mount the rims and tires.
16. Torque down the rims to the correct setting based on the types of rims that you have and their manufacturer's settings.

## **DO NOT TEST DRIVE THE VEHICLE YET!**

1. **A DUAL RESERVOIR BRAKE MASTER CYLINDER IS REQUIRED WITH THIS BRAKE CONVERSION KIT.**
2. **A DISC/DRUM PROPORTIONING VALVE OR DISC/DISC VALVE IS REQUIRED TO MAKE THE SYSTEM FUNCTION CORRECTLY.**
3. Failure to install the correct master cylinder and valve will result in poor brake pressure and the lack of stopping power. The type of master cylinder, brake booster and valve that are needed depends on whether you intend to have manual or power brakes, and if the car is disc/ drum or disc/ disc.
4. You need to have a correct dual reservoir master cylinder installed and a correct brake proportioning valve so the application of brake pressure is applied correctly at each of the four wheels.
5. Please contact us for these additional components that we offer specifically for your model car in a variety of attractive finishes and colors.
6. Remember to always test brakes in a safe test environment after adequately bleeding the brakes.
7. Thank you for your purchase and enjoy your improved stopping power!

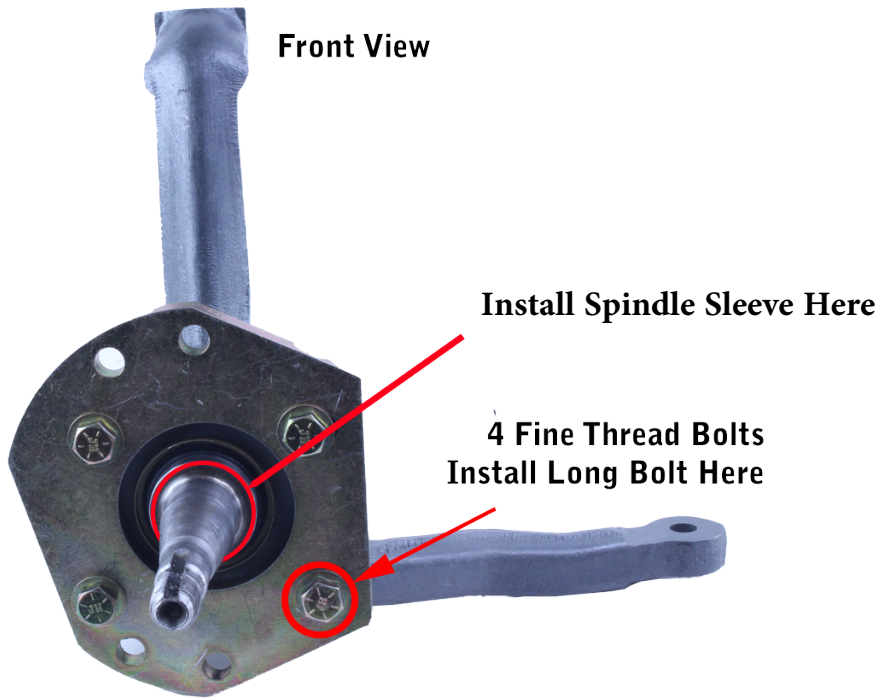

**IMG. 1**

**Spindle Mounting Plate Attached to Drum Spindle**

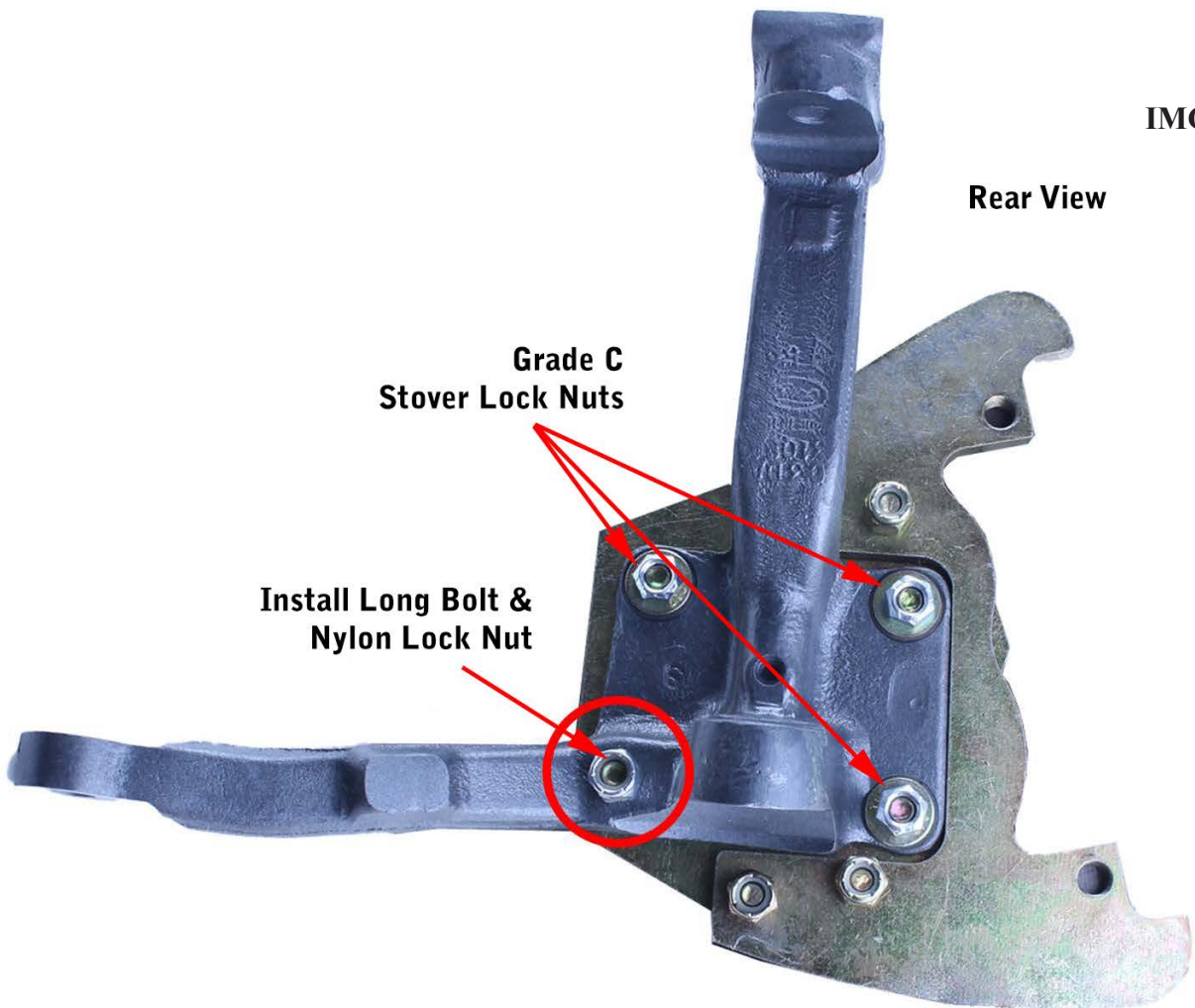

**IMG. 2**

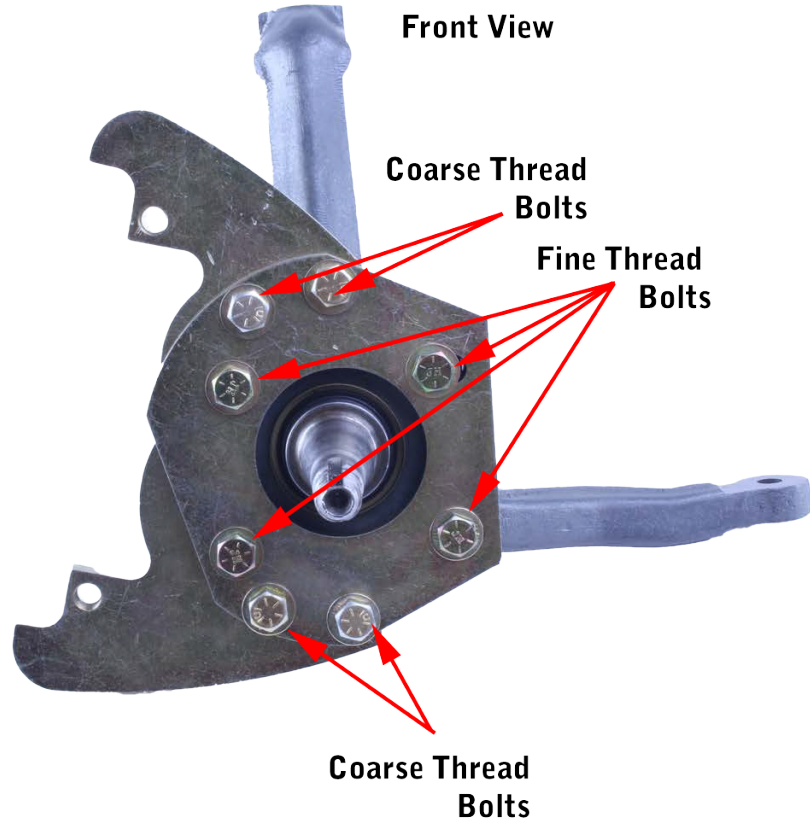

**IMG. 3**

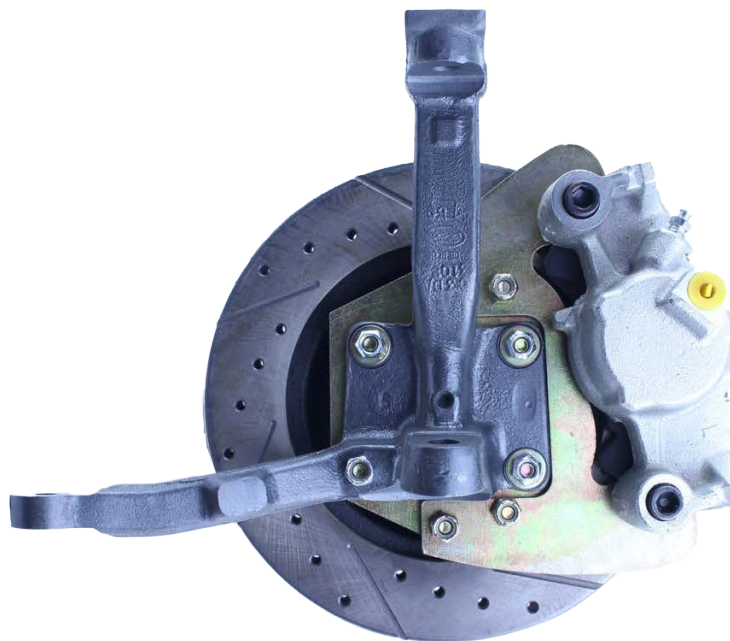

**IMG. 4**