

A.C. COMPRESSOR MOUNT 6-134

289-302-351 w. Ford

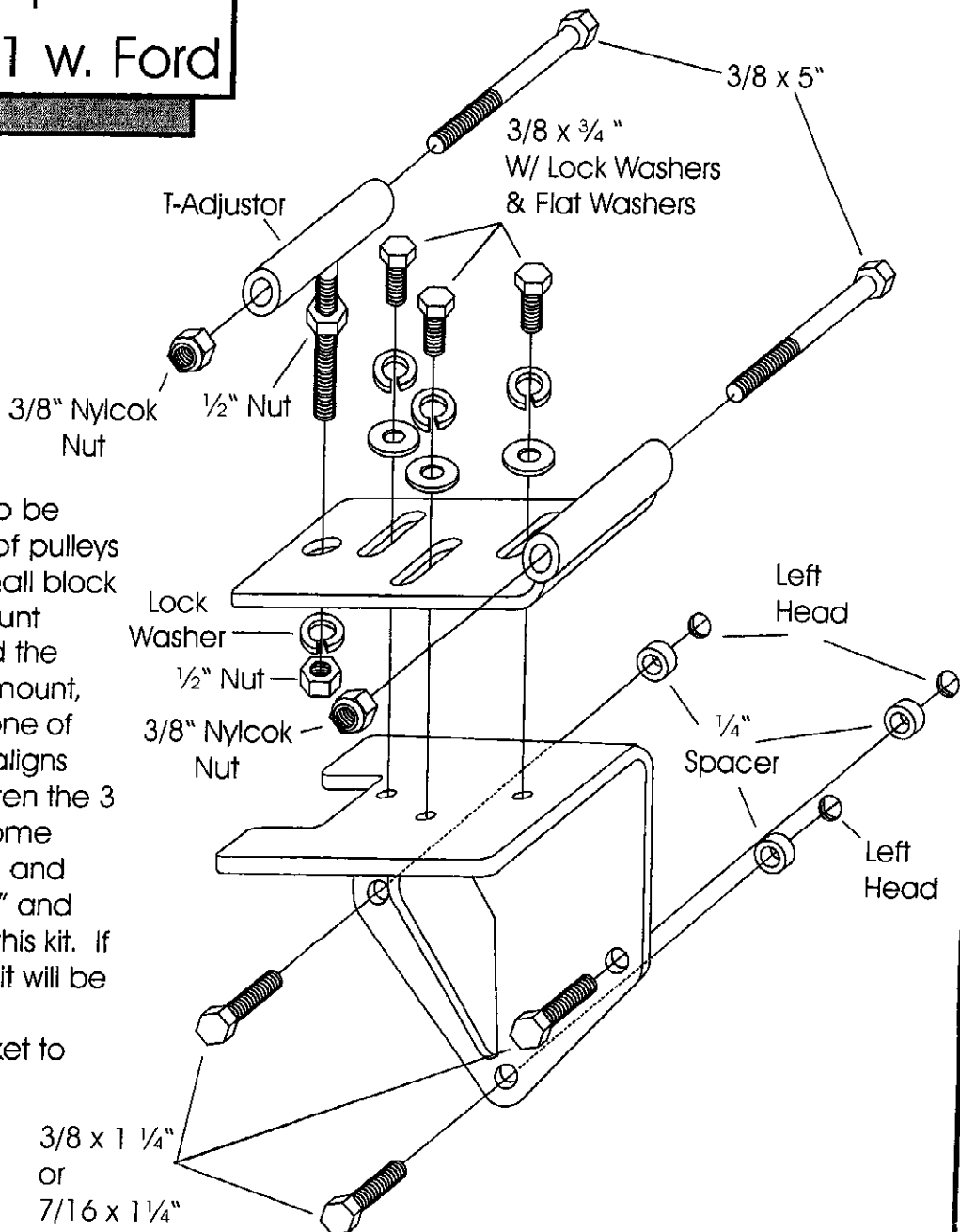

This mount was designed to be used with the wide variety of pulleys and balancers used on small block Ford engines. With the mount bolted to the left head and the compressor bolted to the mount, slide the compressor until one of the grooves on the clutch aligns with your pulleys. Then tighten the 3 bolts, locking it in place. Some Ford heads have 3/8" holes and some have 7/16". Both 3/8" and 7/16" bolts are furnished in this kit. If your head uses 7/16" bolts, it will be necessary to enlarge the 3 mounting holes in the bracket to 7/16".

As with any part of this nature, make sure it fits your application before painting or plating. Parts that have been painted, plated, or modified may not be returned.