

Subframe Connector Kit 4017 64½-70 Ford Mustang

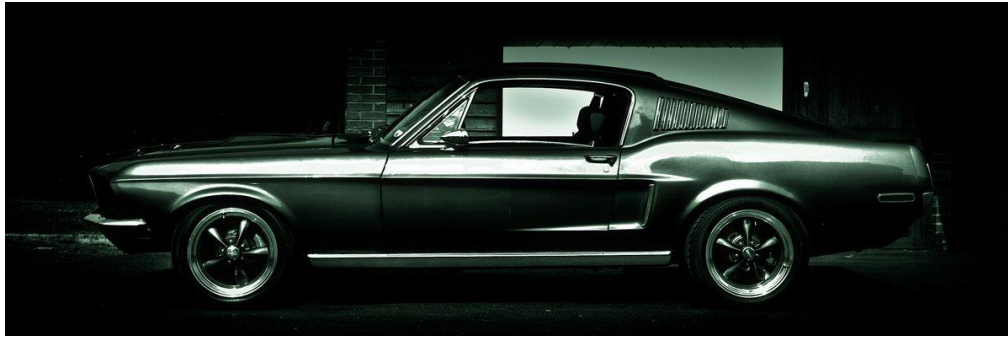

*Thank you for your purchase from our new line of Ford parts.
Please call us at 877 - 4NO - ROLL if you have any questions
regarding the service or installation of your Hotchkis Performance products.*

IMPORTANT: PLEASE READ THE ENTIRE INSTRUCTION MANUAL BEFORE STARTING THIS INSTALLATION.

Note: This installation requires grinding and welding. You also may be required to re-route the fuel line that runs from the front frame rails to the rear frame rails. This kit should be installed by a professional with experience in this type of install.

Chassis Prep:

- 1 Familiarize yourself with the Underbody
Drive the vehicle on an alignment rack or 4-post lift. You will need to raise the vehicle while the car's weight is on the wheels. This will insure the chassis is loaded in its normal state.



Familiarize yourself with the underbody. The key points are the front frame rails, rear frame rails, and the position of the fuel line.

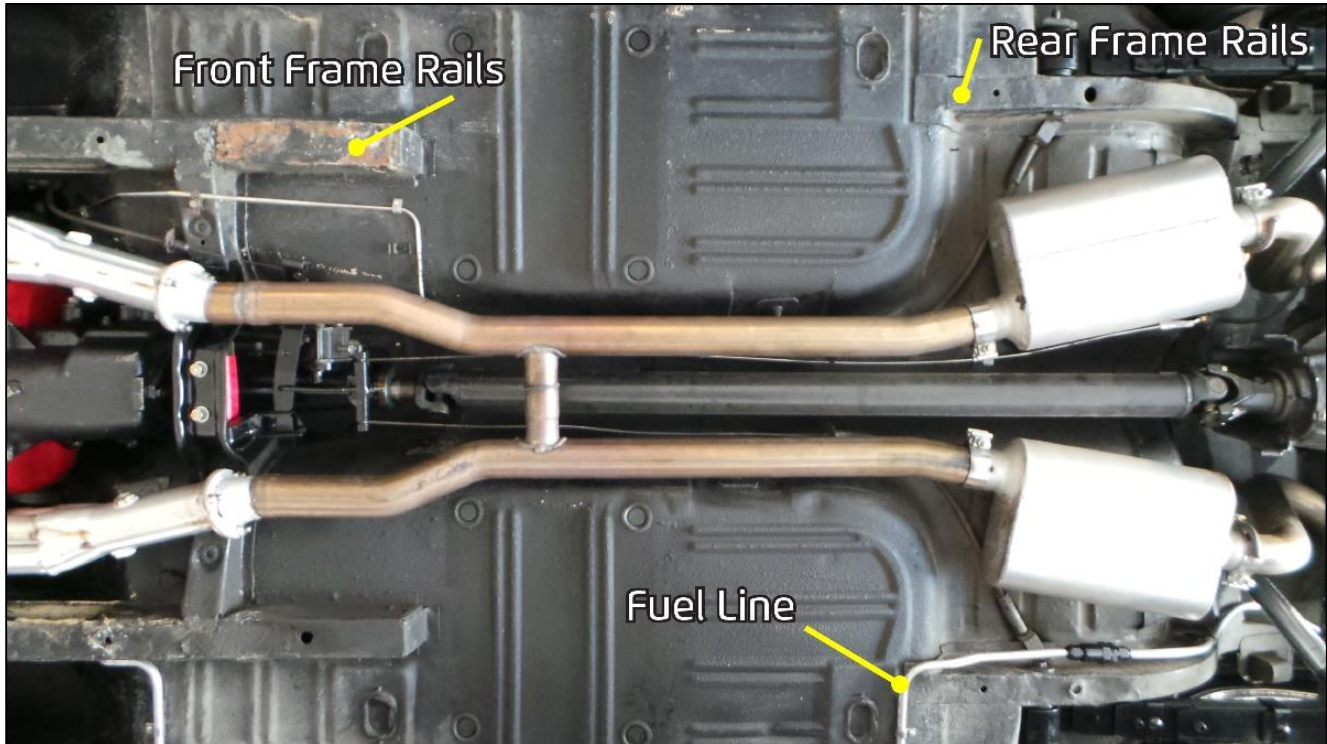

We have seen many different fuel line routing paths on various Mustang years and models, so there is a good chance you will need to modify or re-route the your fuel line to allow clearance for the Hotchkis subframe connectors.

2 Re-route Fuel Line (If necessary)

If your fuel line crosses over from the outside of the frame rails to the inside of the frame rails near the rear frame rails, then you will need to re-route. (See picture below) The subframe connectors mount flush to the floor board & rear frame rails so the fuel line cannot be in this location.

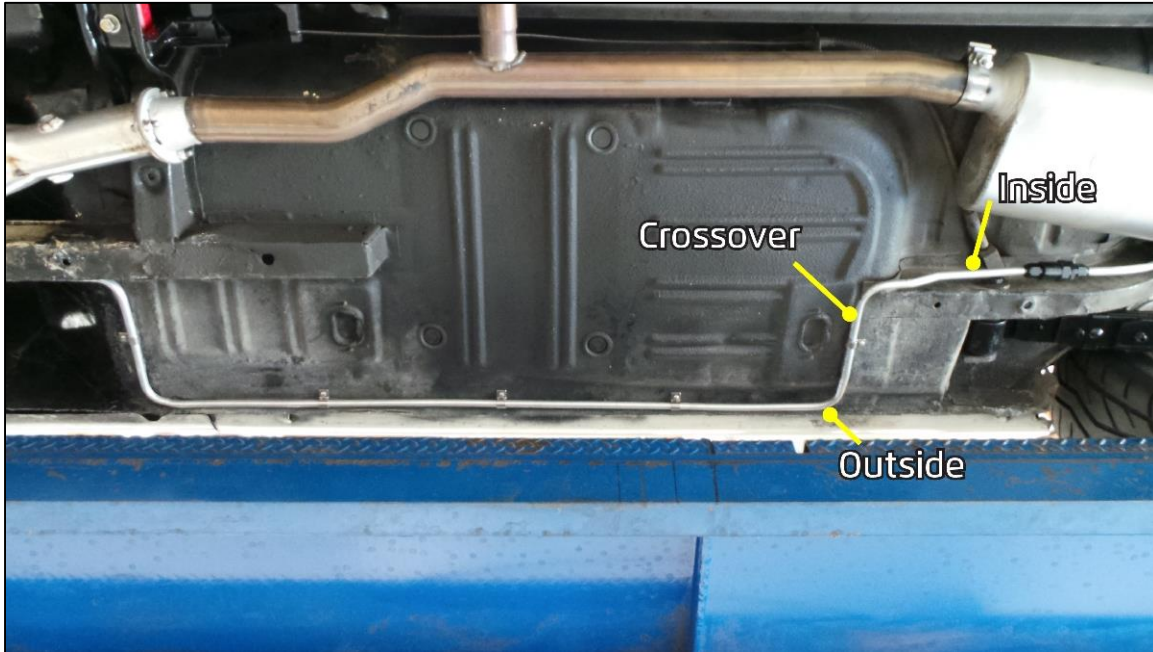

The cross over for the fuel line will need to be closer to the front frame rails. When the subframe connectors are installed, there is a gap between the connector and the floor boards to allow the fuel line to pass through.

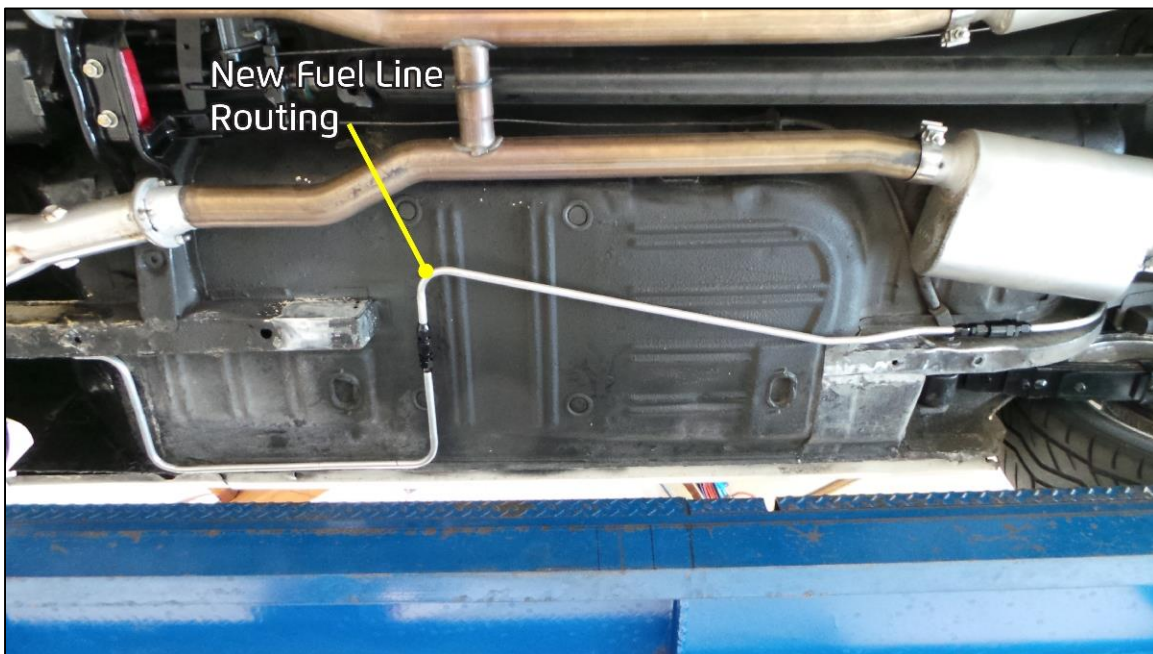

3 Grind old paint/undercoat/rust from Frame Rails

Use an air grinder and remove all old paint/undercoat/rust from the front and rear frame rails. See pictures for the general area that needs grinding. It's a good idea to mock up the subframe connector to the car to see exactly where you need to grind. Once everything is ground to metal, clean the surface to prepare for welding.





Mock Up to See
Where to Grind



Driver Front Frame Rail

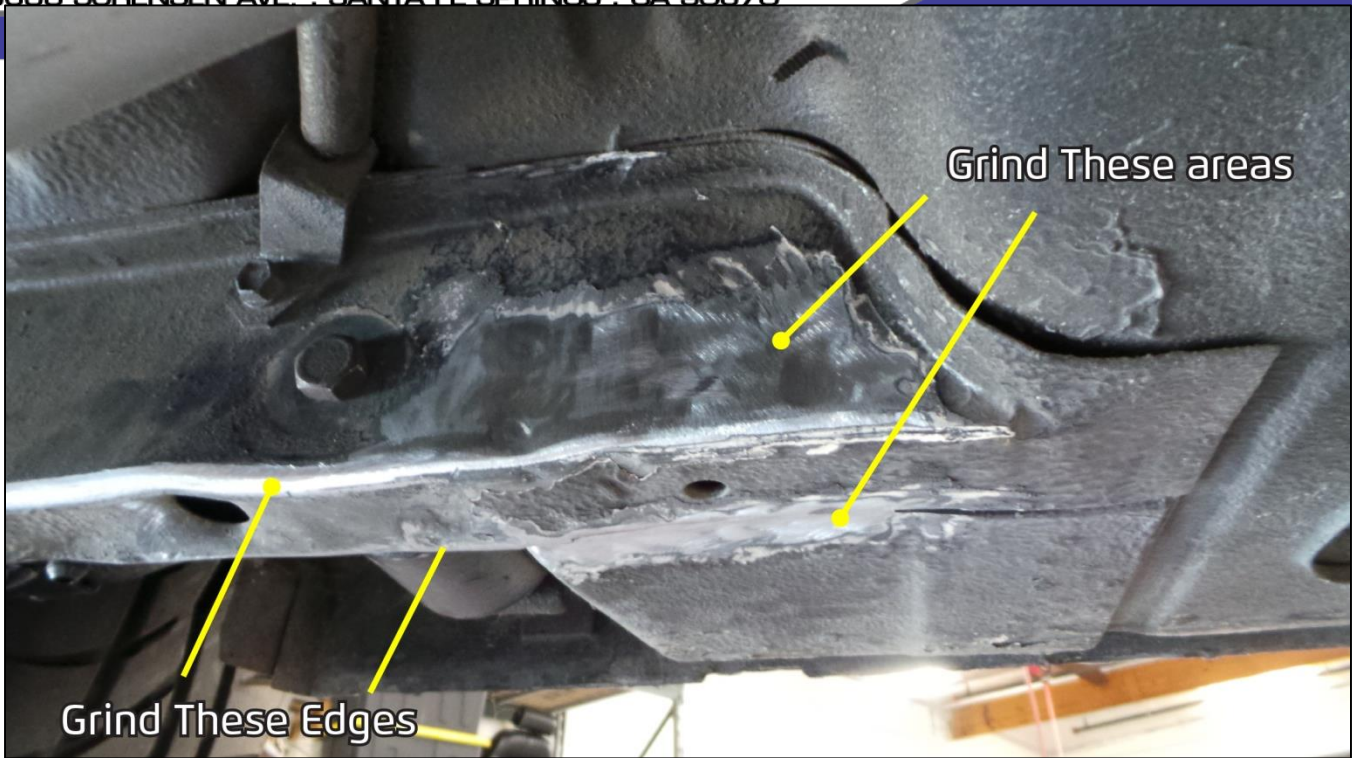

Driver Rear Frame Rail

- 4 **Grind & Clean Weld Area on Subframe Connector**
Use an air grinder to remove the powder coat on the select areas that will be welded. Inner surfaces of holes can be sanded with a round rat tail file or small barrel sander. Clean residue from sanded areas.



Passenger Side Shown

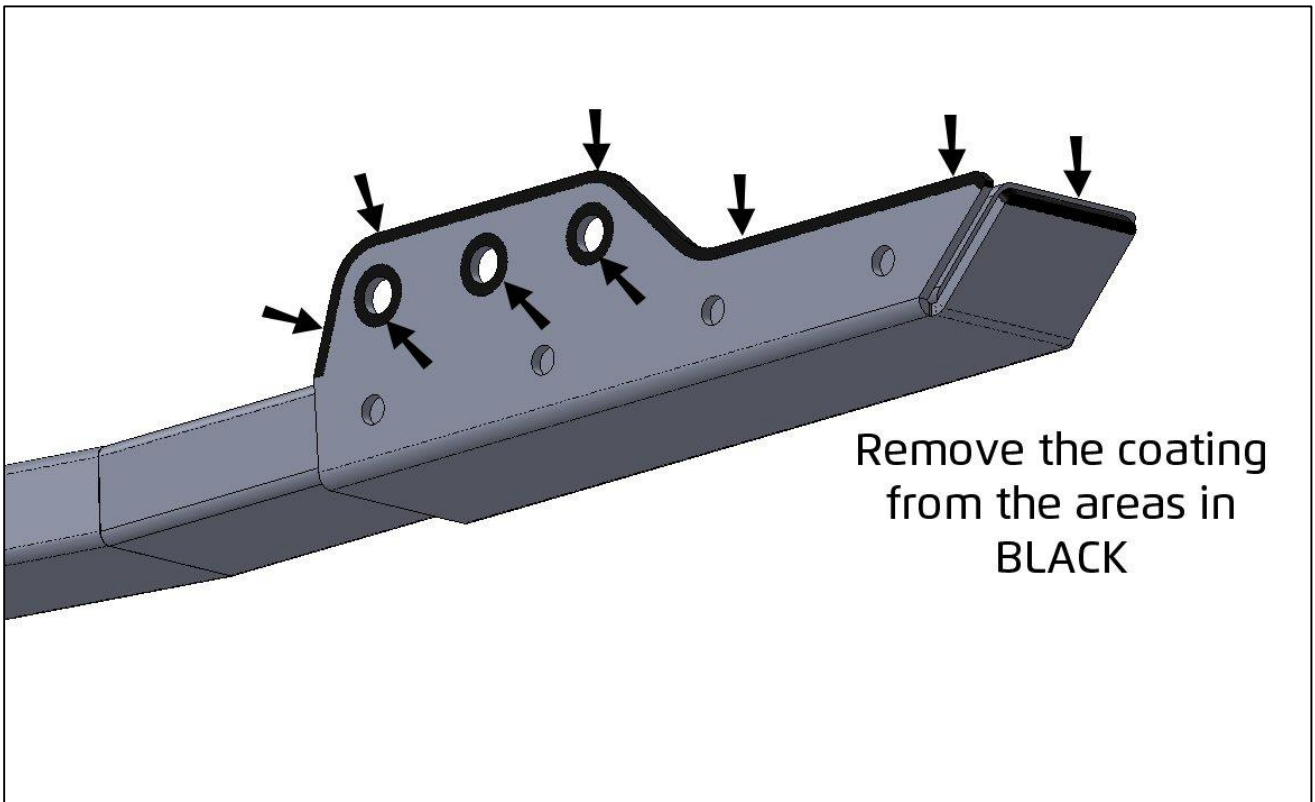
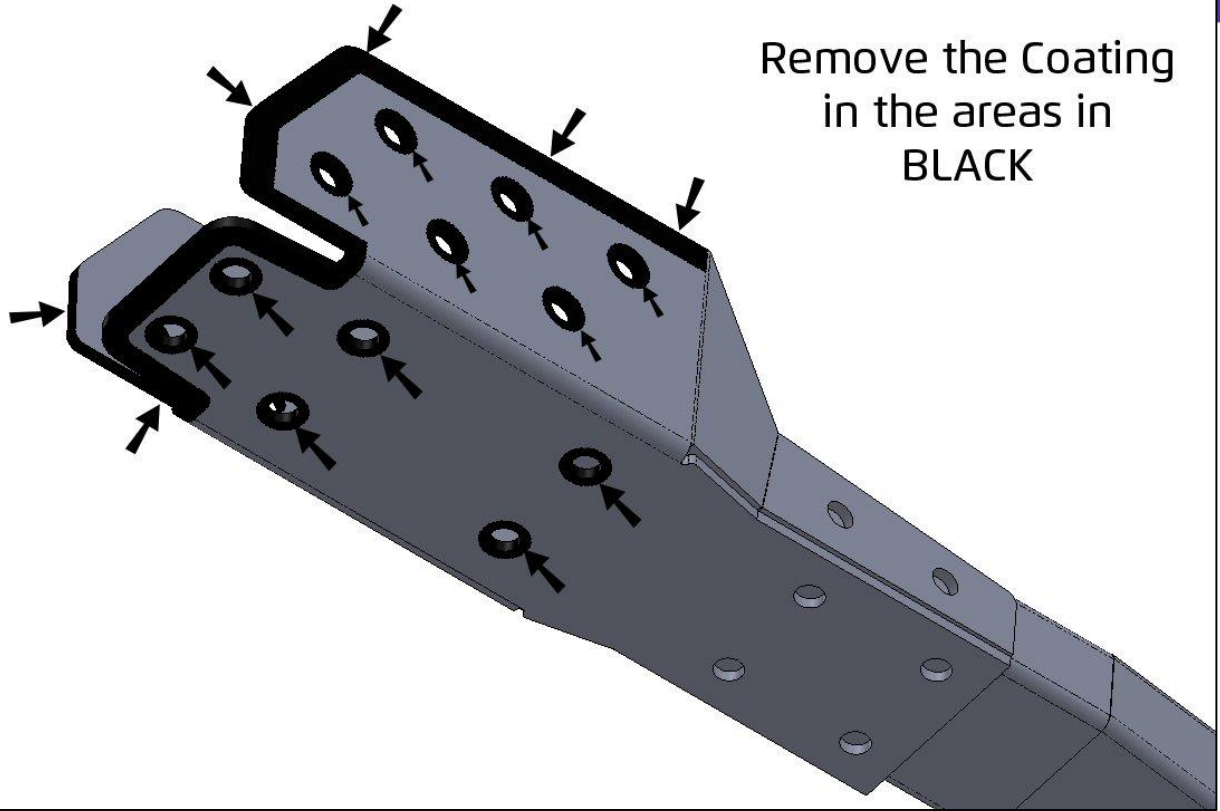

Remove the coating
from the areas in
BLACK

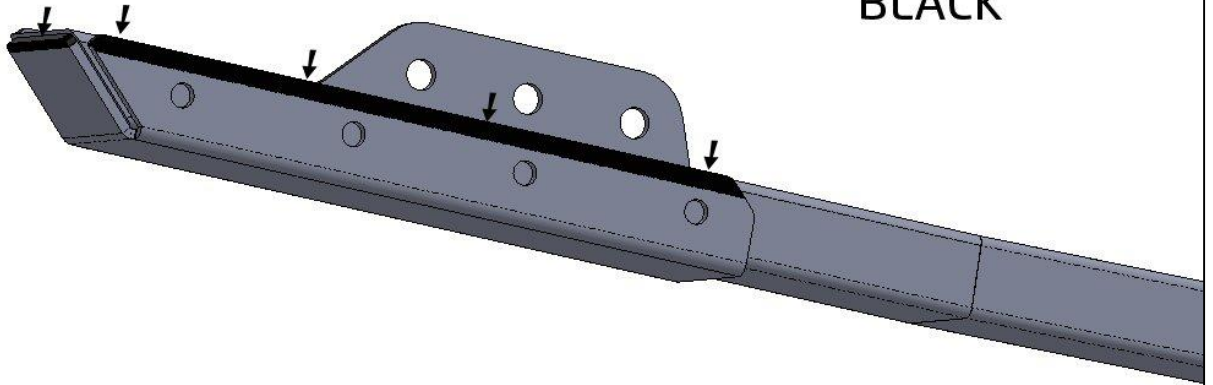

- 5 Weld Subframe Connectors
- Position the subframe connectors up to the car and support with a screw jack.



- Take precautions to protect the fuel line while welding to avoid a fire.
- The front mounting bracket should slide over the front frame rail and should stop when pushed up and forward. If your frame rails are deformed from prior damage, you may need to repair the warpage before the connector can mate to the rail.
- The rear mounting bracket should mate flush and parallel along the rear frame rail. The trailing edge should mount flush to the rail.

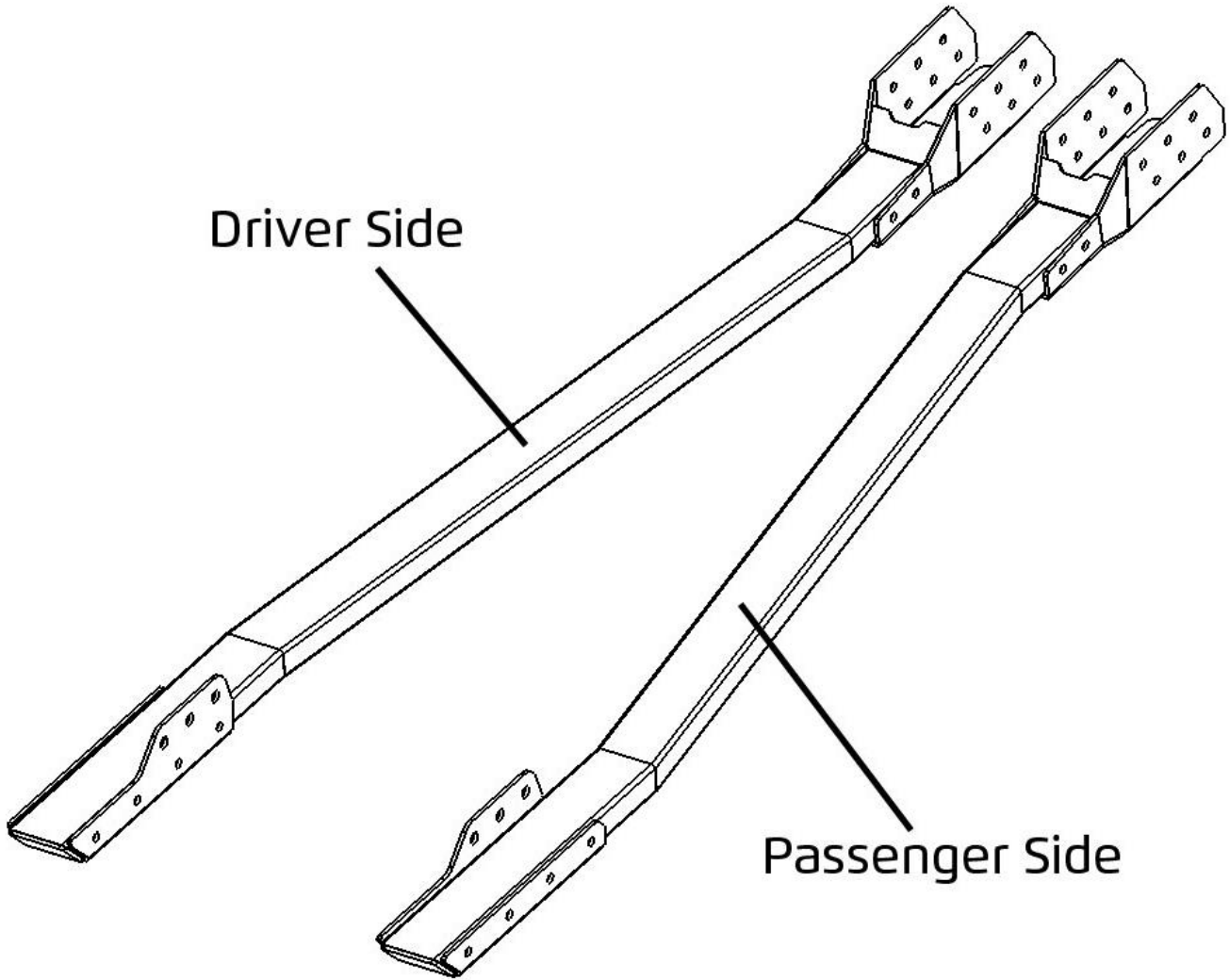

Weld Shaded area

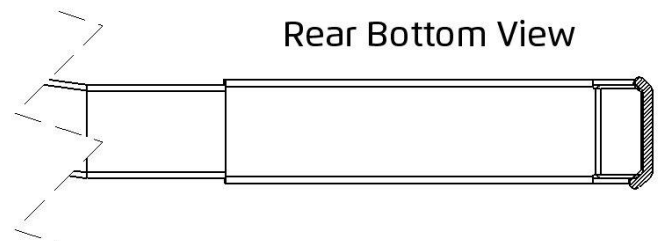
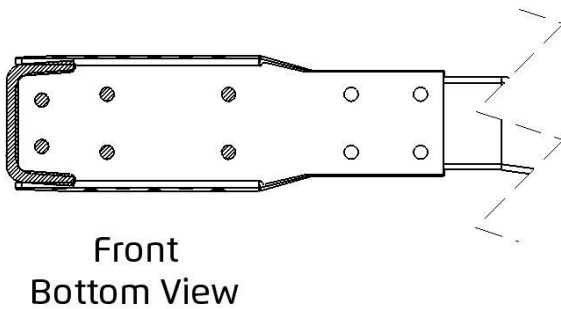
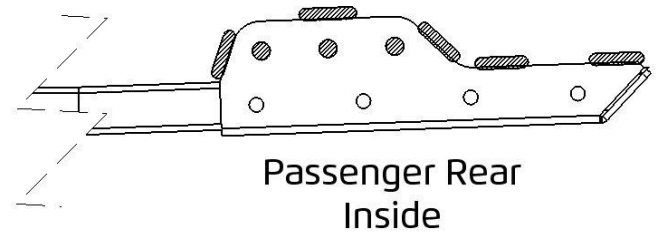
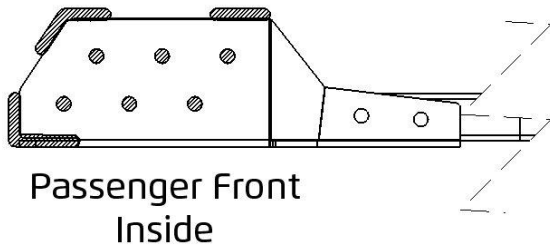
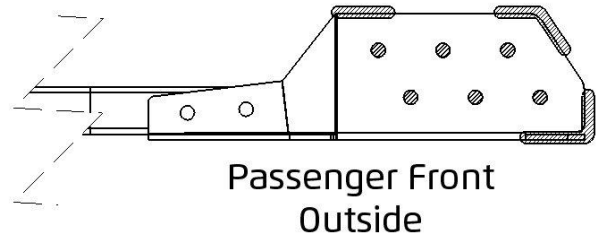
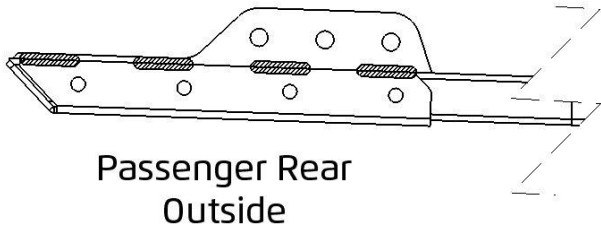

- 6 **Paint the exposed Areas**
Once all of the welding is complete. Clean the exposed area and paint with semi-gloss black. You are now finished with the Hotchkis subframe connector installation.

All information contained herein is subject to change without notice. BUYER'S ACCEPTANCE OF DELIVERY OF THE PRODUCT CONSTITUTES BUYER'S ACCEPTANCE OF THE TERMS HEREIN. ANY ADDITIONAL OR DIFFERENT TERMS PROPOSED BY THE BUYER ARE HEREBY REJECTED IN THEIR ENTIRETY UNLESS EXPRESSLY AGREED TO IN WRITING BY SELLER'S AUTHORIZED AGENT.

TERMS

Prepaid, Visa, MasterCard. Net 30 days from invoice date terms are available after credit approval. Accounts with invoices past due will be placed on "Credit Hold". A finance charge of 1.5% per month will also be applied to all past due invoices, not to exceed the maximum charge permitted by law. Accounts are considered paid in full upon Hotchkis Performance Inc.'s receipt of the full invoice amount plus collection fees and expenses incurred, if any. NSF checks stop payment checks, chargebacks on credit cards, etc. are charged a minimum of \$35 fee. No deduction or credit may be taken for any reason unless a credit memo has been issued by Hotchkis Performance Inc. Any unauthorized deduction will automatically put the account on credit hold. Other product special orders require a 50% down payment and are also non-cancelable and non-returnable.

DROP SHIPMENTS & REFUSED PACKAGES

Drop shipments are charged a \$30 service charge. A 20% restocking fee and all shipping costs are charged to the ordering party if a package is refused. No international drop shipments.

RETURNS

All returns are subject to prior authorization from Hotchkis Performance Inc. Once authorized, a Return Merchandise Authorization (R.M.A) will be issued. All authorized returns must have the R.M.A number on all cartons and shipping documents. Returned product must be shipped prepaid – collect shipments will be refused. Modified or used products are not eligible for return. Returns **MUST** be made within 90 days of invoice date and are subject to a **20% restocking fee. No returns are accepted after 90 days.** Freight charges are not refundable unless the merchandise is defective as determined by Hotchkis Performance Inc. Special orders are not returnable.

DAMAGED SHIPMENTS / SHORTAGES

All Hotchkis Performance Inc.'s shipments are F.O.B. our factory. Title passes from Hotchkis Performance Inc. to the purchaser at the time is shipment initiated. Claims for Carton shortages and damages must be made against the carrier at the time of delivery. To expedite processing of claims against the carrier, the customer must note damages on the bill of lading at the time of the delivery, and promptly request an inspection by the carrier or its claims agent. If a shortage is found within the shipment, it must be reported to Hotchkis Performance Inc. in writing within five (5) business days of receipt of shipment. Claims need to include the following information order number, invoice number, date of invoice, date of shipment, part number, description and carton count.

PRODUCT SUBSTITUTION / OTHER

Hotchkis Performance Inc. reserves the right to substitute equal or better materials or products at its discretion. Hotchkis Performance Inc. reserves the right to change specifications and other information included in this catalog without notice. All information, data and dimension tables in this catalog have been carefully compiled and thoroughly checked. However, no responsibility for errors or omissions can be assumed. Some parts may not be legal for sale or use in certain states, including California, on certain pollution-controlled motor vehicles. It is the purchaser's responsibility to determine if any parts they purchase are suitable for their particular locale and use.

WARRANTY / DISCLAIMER

Hotchkis Performance Inc. warrants that the products will be free from defect in material and workmanship for three years from date of sale to the original purchaser. Hotchkis Performance Inc. makes no other warranty of any kind, express or implied. Hotchkis Performance Inc. shall have no obligation under the forgoing warranty where the defect is the result of improper or abnormal use, user's negligence, vehicle accident, improper or incorrect installation or maintenance, nor when the product has been repaired or altered in any way. Hotchkis Performance Inc.'s liability in the case of defective products subject to the forgoing warranty shall be limited solely to the repair or replacement, at Hotchkis Performance Inc.'s option, of the defective products. Hotchkis Performance Inc. will be the sole judge of the validity of warranty claims.

Consequential or incidental damages are not recoverable under this warranty. Some states do not allow the exclusion or limitation of incidental or consequential damages, so the above limitation or exclusion may not apply to you. This warranty gives you specific legal rights, and you may also have other rights which vary from state to state.

In order to be eligible for service under this warranty, the defective part(s) must be returned to Hotchkis Performance Inc. by the original purchaser together with the R.M.A number issued from Hotchkis Performance Inc. and a copy of the receipt showing purchase within past 3 years. Tag each item with the part number and the specific explanation of defect. We will inspect the part and determine: a) if it is eligible for repair or replacement; and, b) if so, whether to repair or replace it. All returns must be shipped **prepaid** to:

Hotchkis Performance Inc.
RMA # _____
118 Infield Court
 Mooresville, NC 28117

Hotchkis Performance Inc. will return all products covered under warranty to you by ground freight at Hotchkis Performance Inc.'s expense. Any expedited freight is the responsibility of the customer.

THE BUYER UNDERSTANDS AND EXPRESSLY RECOGNIZES that ALL parts and services sold by Hotchkis Performance Inc. are exposed to many and varied conditions due to the manner in which they are installed and used. BUYER ACKNOWLEDGES that HOTCHKIS PERFORMANCE INC. does not have full knowledge of the intended use of goods, and BUYER WILL DEFEND AND INDEMNIFY HOTCHKIS PERFORMANCE INC. upon demand against all claims, actions, liability, loss and expense (including investigating expense and attorney fees incurred in litigation or because of threatened litigation) for any loss, damage or injury, either to a person or to property, resulting from the direct or indirect use of any Hotchkis Performance Inc. products or inability by the buyer to determine proper use or application of Hotchkis Performance Inc. products. With the exception of the limited liability warranty set forth above. Hotchkis Performance Inc. SHALL NOT BE LIABLE FOR ANY CLAIMS, DEMANDS, INJURIES, DAMAGES, ACTIONS, OR CAUSES OF ACTION WHATSOEVER TO BUYER ARISING OUT OF OR CONNECTED WITH THE USE OF ANY HOTCHKIS PERFORMANCE INC. PRODUCTS

MOTORSPORTS AND SIMILAR ACTIVITIES ARE DANGEROUS; AS SUCH, NO WARRANTY OR REPRESENTATION IS MADE AS TO THE PRODUCT'S ABILITY TO PROTECT THE USER FROM INJURY OR DEATH. THE USER ASSUMES THAT RISK