



WARNING:
 Validate the kit contents with the component list included on this page before proceeding. This kit is intended to be used in a modified vehicle. Please read this page thoroughly and be sure that you understand everything explained on it prior to opening any of the enclosed packages, or before attempting to install any of the components. Once this kit has been opened or a component installed, the kit is not returnable.

1. This new updated American Autowire wiring system **WILL NOT SUPPORT** the factory Ford EEC computerized systems (carbureted or fuel injected), and should typically be used in a **MODIFIED** application only. It will work with the factory Ford Dura-Spark, HEI, or other aftermarket ignition and fuel injection systems.
2. This kit includes the wiring to support the use of a factory heater system and/or aftermarket heater and A/C systems. This kit does not include the wiring for the factory original A/C system. Optional, extra cost, **A/C Kits (510482 - 1980-83; 510483 - 1984-86)** are available that will allow you to use your original factory A/C components.
3. This kit only supports the use of a higher current, self-exciting 1-wire alternator or an internally regulated alternator. Optional adapters may be necessary for certain applications. AAW offers a Ford Gen III adapter, P/N 500802, at extra cost.
4. AAW **DOES NOT** support the use of an ammeter. All AAW kits are engineered to supply the optimum charge to the battery. To achieve this performance, we route our 6 gauge charge wire from the alternator output charge terminal to the starter relay battery terminal. Due to the path of the charge being altered from the stock configuration, the gauge can no longer see a charge vs. discharge. **This wiring system has been designed to work with a voltmeter.**
5. This kit **IS NOT** set up with a resistance wire for a standard, points type ignition system. It is wired with a full 12-volt primary ignition feed. See **pages 24 and 25** for the various Ignition System Wiring configurations.

510724 - Classic Update Series Kit 1980-86 Ford F-Series and Bronco

This kit contains the following components:

Bag	Number	Description	Quantity
	500042	Floor Dimmer Switch	1
	510264	Headlight Switch	1
	510346	Wiper Switch	1
	510697	Fuse, Relay, and Flasher kit	1
	500919	Practice Terminal Crimping Set	1
G	510725	Dash Harness kit	1
H	510726	Instrument Cluster wiring kit	1
J	510727	LH Engine Wiring Kit	1
L	510728	RH Engine Wiring Kit	1
M	510729	Rear Body Wiring kit	1
Z	510476	Alt. & Main Power Connection Kit	1
	92972233	Firewall Template	1

Validate the kit contents with this component list. If there are any discrepancies with incorrect or missing parts, stop your installation and notify the supplier you purchased the kit from before proceeding.

510724 1980-86 Ford F-Series and Bronco Classic Update Series



**American
 Autowire**

© COPYRIGHT 2004 American Autowire / Factory-Fit
 American Autowire / Factory-Fit

www.americanautowire.com 856-933-0801 92972210 Rev 0.1 10/30/2019

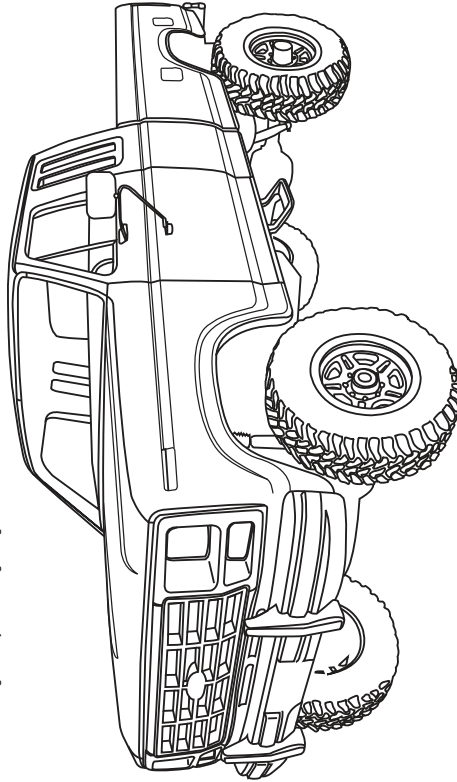

START HERE !

PLEASE READ THIS BEFORE STARTING INSTALLATION !

This wiring kit is designed for ease of installation. Please read the guidelines below, BEFORE STARTING your installation, to guarantee a successful job. Use an appropriate crimping tool, which folds the wings of the open barrel terminals down into the wire, as shown on this page. If you use our crimping tools and correctly crimp the included terminals, soldering is not necessary. If you are unsure about a particular crimp, soldering is recommended. Our factory crimped terminations are installed by GM approved five ton presses, and soldering these terminations is not necessary.



AAW offers a great terminal crimping video entitled "Proper Crimping Video". It can be viewed by visiting YouTube.

Type the following address into your web browser, to go directly to the video:
www.youtube.com/watch?v=JAgEDoVl-co

Youtube Channel:
www.youtube.com/user/WiringHarness

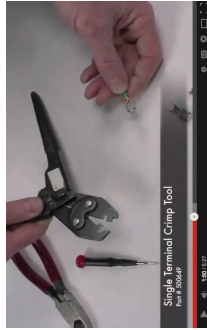

The terminals that we supply in our kits, utilize what is known as an F crimp. The F crimp, in a cross section, will look like the illustration below, when done correctly.

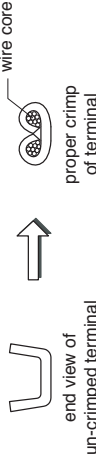

We carry the following crimping hand tools, to help with your terminal crimping. These hand tools are available, for purchase or rental.

p/n 510585
 OEM small terminal crimping tool (18-14 gauge)



p/n 510586
 OEM large terminal crimping tool (12-8 gauge)



p/n 510587
 Includes Both terminal crimping tools

We carry many accessories for your 1980-86 Ford truck or Bronco:



p/n 510482
 80-83 Optional A/C Overlay Harness



p/n 510483
 84-86 Optional A/C Overlay Harness



p/n 510484
 80-86 Optional Dual Fuel Tank Harness



p/n 510485
 81-86 Optional Bronco Rear Destroster Harness



p/n 510486
 80-86 Optional Bronco Rear Tailgate PW Harness



Page 2
www.americanautowire.com 856-933-0801

If you have any questions concerning this or any of our products, please feel free to call us at 1-856-933-0801.

510724 1980-86 Ford F-Series and Bronco Classic Update Series

92972210 Rev 0.1 10/30/2019

STEP 1: DISCONNECT YOUR BATTERY

Disconnect the battery before installing the wiring kit. This is to prevent any accidental shorting caused by bare wire ends.

STEP 2: LOAD THE FUSE BLOCK

Prior to installing the Dash harness to the dash, obtain the Fuse, Flasher, and Relay Kit 510697 and plug all of the fuses and the flashers to the Fuse Block (see below). Plug the Horn Relay to the Dash harness (see below).

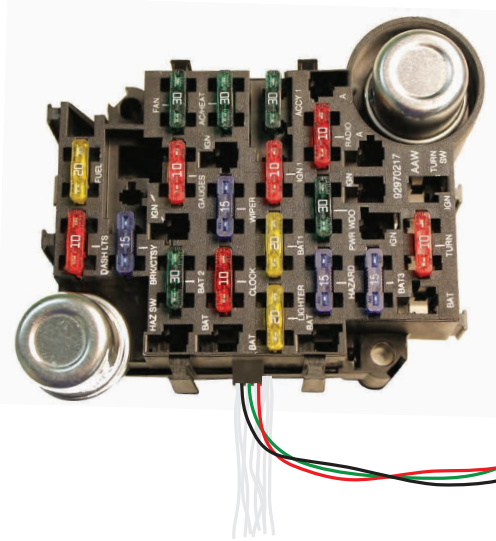

Fuse usage details. NOTE: Park, Tail and Head lights are protected by the H/L switch internal breaker

Fuse #	Fuse Block Printing	Fuse Rating	System Wiring Protected
1	DASH LTS	10A	Cluster lights, headlight / wiper switch light, heater control light, ashtray light, optional dash lights plugged into candelabra, PRNDL indicator light, Bronco rear defroster module illumination light.
2	FUEL	20A	Electric fuel pump, electric speedo feed, dual tank solenoid (Aczy 6-way conn).
3	BRKCTYS	15A	Stop and third brake lights, courtesy lights, dome and map light, glove box lamp, Bronco rear cargo / courtesy lamp.
4	BAT 2	30A	Power seats, bat. feed Bronco rear window defroster module (Aczy 6-way conn), optional tachometer, alternator/gauge power.
5	GAUGES	10A	Oil pressure warning light, brake warning light, backup lights, 4x4 indicator light, optional tachometer, alternator/gauge power.
6	FAN	30A	Electric fan.
7	CLOCK	10A	Battery feed for digital clock, radio battery feed.
8	WIPER	15A	Wiper motor, washer pump feed
9	ACHEAT	30A	Air conditioning/heater feed.
10	LIGHTER	20A	Lighter, battery feed in rear body, underhood lamp feed
11	BAT 1	20A	Power locks (Aczy 6-way conn).
12	IGN 1	10A	Electric choke.
13	ACCY 1	30A	Opt. accessory feed, Bronco rear defroster module relay coil (Aczy 6-way conn).
14	HAZARD	15A	Hazard lights.
15	PWR WDO	30A	Power windows, Bronco tailgate power window feed (Aczy 6-way conn).
16	RADIO	10A	"On-off" feed for radio and digital clock.
17	BAT 3	15A	Opt. battery feed. (Aczy 6-way conn).
18	TURN	10A	Turn signals.

STEP 3: PREPARING TO INSTALL THE DASH HARNESS

Remove the dash frame assembly from the vehicle. Strip the original dash/main harness off of the dash frame (see photos 1 and 2 on page 6).

STEP 4: RECLAIMING YOUR ORIGINAL FIREWALL GROMMETS

We recommend that you re-use the factory firewall grommets from your original harness. See pages 19 or 22 for specific details on splitting and removing your original grommets. In the event that your originals are not serviceable, we have provided new replacements.

STEP 5: DRILL THE FUSE BLOCK MOUNTING HOLES

Obtain the Fuse Block Mounting Instructions 92972233 and drill a new 1/8" hole in the firewall per those instructions. This will prepare the firewall so that it's ready to accept the new dash harness and fuseblock assembly.

STEP 6: INSTALL THE CLIPS AND J-CLAMPS

(See page 5) Obtain 9 of the "1" routing clips "L", one of the J-Clamps "J", with one each of the screws, washers and nuts "K, G and H" (2 extra J-Clamps have been provided in case your dash conduit over top of the heater control is missing), and two of the edgebliter clips "R" and install them all onto the dash frame shown on page 7 of this instruction set.

STEP 7: START INSTALLING THE KIT

This kit is broken down into individual sections that are identified by a letter printed on the enclosed sheets, visible through each bag. The order of installation and the pages with their installation instructions are shown on page 4.

**510724 1980-86 Ford
F-Series and Bronco
Classic Update Series**

92972210 Rev 0.1 10/30/2019



www.americanautowire.com 866-933-0801

Table of Contents:

Bags: Pages:

G 5-12

Dash Harness (510725) (Part 1 Installation) – This is the main harness in the kit and it should **first** be installed to the dash frame assembly. Install the main trunk of the Dash Harness into the frame as shown in the pics. The Dash Harness contains:

- | | | |
|--|--|---|
| Instrument Cluster Harness connections | Digital Clock connection | Tachometer Ground connection |
| Headlight Switch connection | In-Line Heater connections | 4 x 4 Indicator Light connection |
| LH and RH Courtesy Light connections | Ground connections | Radio wires |
| Cigar Lighter connections | Ash Tray Light connection | Headlight and Wiper Light connection |
| Heater Switch connection | Glove Compartment Light connections | Electric Speedometer Ground connection |
| Wiper Switch connection | Heater/AC and Optional Rear Defroster Light connections | Dash Light Candelabra (optional lamp use) |
| Horn Relay connection | Optional Accessory Power Feed connection (see page 10 details) | In-Line Fuel Gauge connections |

Dash Harness (Part 2 Installation) – After installing the Dash Harness to the dash frame assembly, now install the entire assembly back into the vehicle. Attach the Fuse Block Assembly to the firewall as outlined in Step 5, on page 3 of this instruction set. The Dash Harness now connects to the following components:

- | | | |
|--|--|--|
| Ignition Switch connection | Turn Signal Switch connection | Back Up Light Switch Extension connection |
| Stop Light Switch connection | Clutch Interlock/ NSS connection | LH & RH Door Jamb Switches |
| Rear Body Harness connection (exterior) | Rear Body Harness connection (dome light and interior) | LH Fender Apron Extension connections |
| Wiper Switch/Extension connection | Park Brake Switch connection | LH and RH Forward Lighting Extension connections |
| Dimmer Switch connection | Heater Resistor / Blower Motor Extension connection | Vehicle Speed Sensor Extension connection |
| AC Overlay Feed connections (optional use) | Engine, Ignition, Starter Relay Extension connections | Main Power Feed connection |

H 13-16 **Instrument Cluster Harness (510726)** – This harness is assembled by the customer and connects to:

- 1980-86 w/Temp. Oil and Fuel Gauges (Ammeter not supported, with or w/o optional tach)**
 Printed Circuit Board (PCB)
 Dash Harness connections

17 **Aftermarket Gauges**

All gauges

J 18-20 **LH Engine Harness (510727)** – This harness connects to the dash harness and:

- LH Headlight
 LH Parking/Turn Lamp
 LH Side Marker
 Wiper Motor
 Washer Pump/Reservoir
 Horns

- Brake Warning Switch
 Electric Fan (requires an optional Relay Kit)
 Back Up Lead Extension Wires



www.americanautowire.com 856-933-9801

L 21-25 **RH Engine Harness (501728)** – This Harness connects to the dash harness and:

- RH Headlight
 RH Parking/Turn Lamp
 RH Side Marker
 Ignition System
 Starter Relay
 Main Power Feed, Alternator Exciter Feed

- Electric Choke, Tach, Oil Pressure and Water Temperature Senders
 Heater Resistor and Blower Motor

M 26-33 **Rear Body Harness (510729)** – Interior and exterior connections. This harness connects to:

- Dash Harness
 Tail Light Extensions (Stop Tail and Back Up)
 Underhood Lamp Feed
 Fuel Tank Lead and Sender Extensions
 License Lamp connections
 4 x 4 Transfer Case Extension Lead

- Dome Light, Dome/Map Light
 Third Brake Light
 Bronco Rear Courtesy/Cargo Lamp

510724 1980-86 Ford F-Series and Bronco Classic Update Series

Dash/Main harness installation instructions:

Below are the supplied misc. terminals, connectors and assorted components included in the Dash/Main Harness and Loose Piece bag (92972215). These will be used to complete your Dash/Main harness connections and are referred by the letters and descriptions below from this point forward.

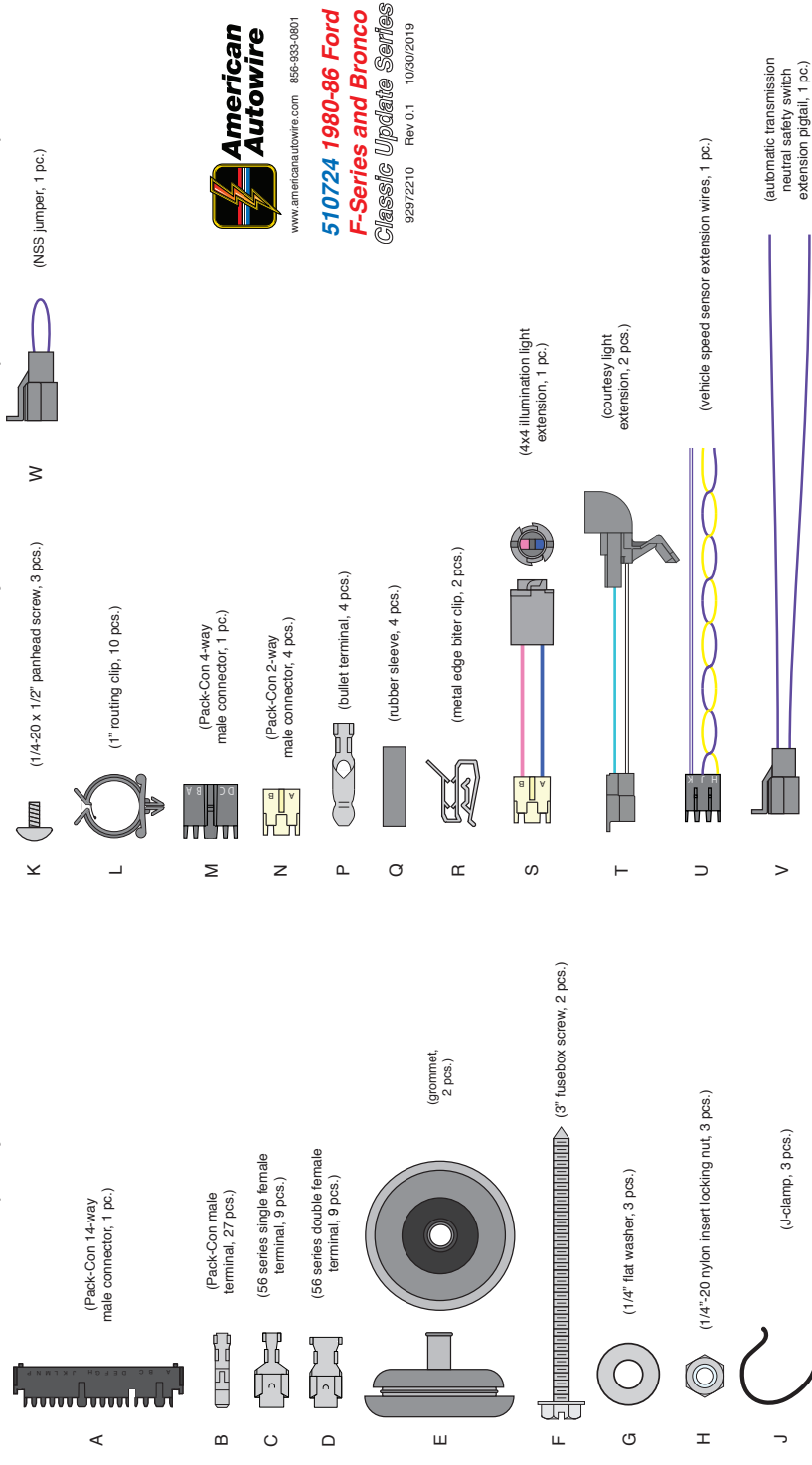

www.americanautowire.com 856-933-0801

**510724 1980-86 Ford
F-Series and Bronco
Classic Update Series**

92972210 Rev 0.1 10/30/2019

Dash/Main harness installation instructions:

929722:10 Rev 0.1 10/30/2019



Complete dash assembly removed from the vehicle

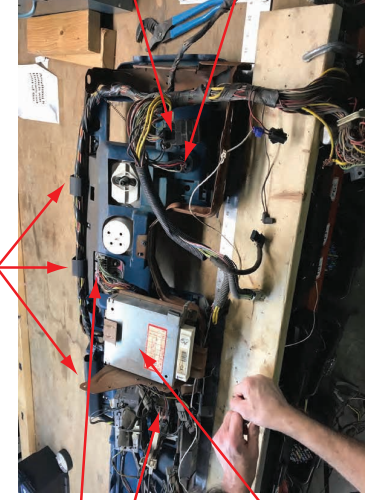

Cluster connector

Heater connector

H/L switch connector

Wiper switch connector

Original EEC module. (To be removed)

1. Disconnect all the underhood wiring from the senders, lamp assemblies, etc. Unseat the grommets from the firewall of the truck, and push them back inside along with all the wiring. With the help of another person, remove the entire dash assembly from the truck.

2. Place the dash assembly on a clean workbench, face-down. Begin disconnecting all the switch, cluster, lamp and accessory connectors. Remove the EEC as it will no longer be used with this kit (you will need to update your ignition/distributor system)



Heater control and ashtray lamps. Need to cut from your original dash harness. See page 12 for details (to be reused)

Wiper and headlight switch illumination lamp installs here. Need to cut from your original dash harness. See page 12 for details (to be reused)

Install H/L switch here

Install Wiper Switch here

3. View of the driver side dash frame assembly with the original main/dash harness removed. Several dash illumination lamp assemblies will need to be saved and reused (see page 12 for details). Build the dash illumination lamps and install as shown above. The dash harness will plug into these extensions later. Install the new H/L and Wiper switches into the dash frame.

Page 6

4. View of the passenger side dash frame assembly with the main/dash harness removed.

Dash/Main harness installation instructions:

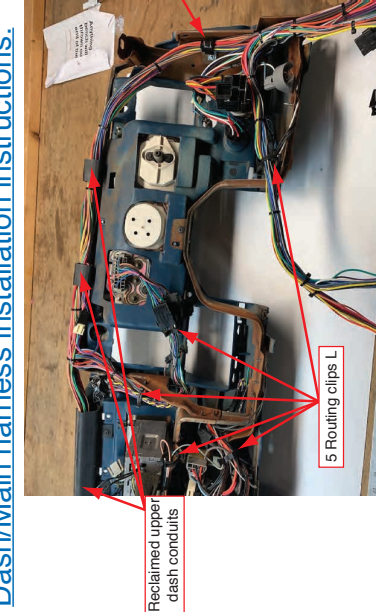

Reclaimed upper dash conduits

5 Routing clips L

J-clamp, screw, washer and nut G, H, J and K

5. With the dash frame stripped of the original harness, install the "J-clamp" using screw, washer & nut "K, G and H" as shown above right. Install 5 routing clips "L" in the locations shown above. Reuse upper dash conduits as shown above. Two J-clamps "J" can be used in place of the long conduit.

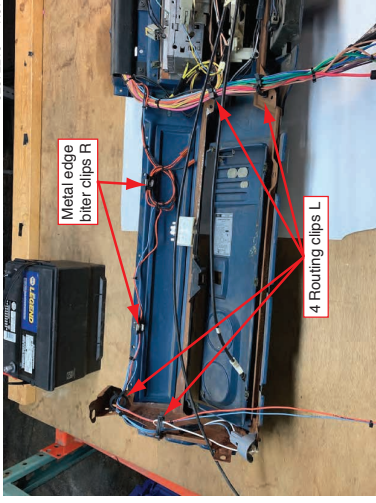

Metal edge biter clips R

4 Routing clips L

6. With the RH side of the dash frame stripped of the original harness, install 4 routing clips "L" in the locations shown above. Install 2 metal edge biter clips "R" onto the plastic dash housing tabs as shown above. Begin installing dash harness (510726) onto the stripped dash frame assembly as shown in 5 and 6.

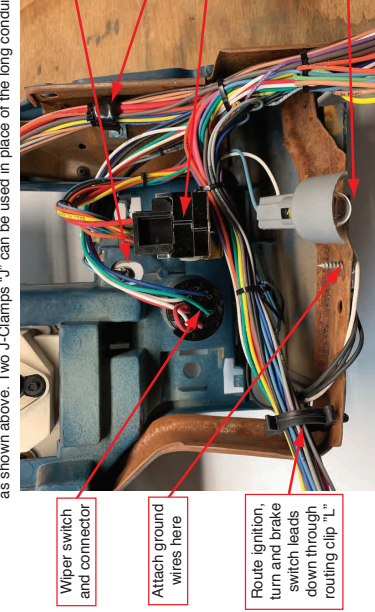

Wiper switch and connector

Attach ground wires here

Route ignition, turn and brake switch leads down through routing clip "L"

Wiper/ head-light switch illumination lamp extension

Route harness under J-clamp

Headlight switch and connector

Attach the plugged-in courtesy lamp pigtail (see page 12) and white courtesy lamp ground wire here

7. Plug the dash harness connectors onto the new wiper switch (510346) and headlight switch (510264) installed into the dash frame. Install underdash courtesy lamp and white courtesy lamp ground wire, black ground wires and wiper/headlight switch illumination lamp as shown. Details for lamp extensions can be found on page 12.

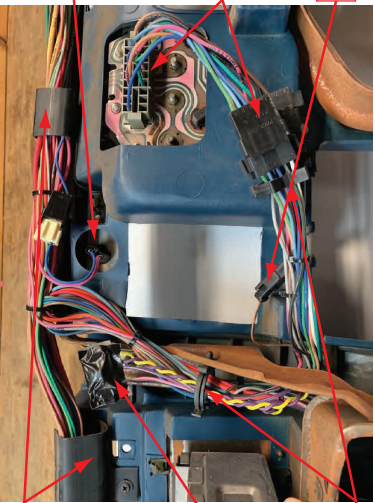

Reclaimed upper dash conduits

Optional electric speedo connection (only used with aftermarket gauges, see dash cluster instructions on page 17.

2 Routing clips "L"

New 4x4 illumination light extension "S"

Dash cluster harness (510726)

Tan fuel gauge lead wires

8. Route the dash harness across the top of the dash assembly and through the upper dash conduits. Install the new 4wd lamp extension "S" (if equipped). Continue routing through clip "L" then over to the cluster area through another routing clip "L". Plug the tan fuel gauge wires together unless you have dual tanks (if you have dual tanks, you'll need to purchase kit 510484). Build the applicable gauge cluster harness, 510726 (see pages 13-17), and plug-in as shown above.

Dash/Main harness installation instructions:

92972210 Rev 0.1 10/30/2019

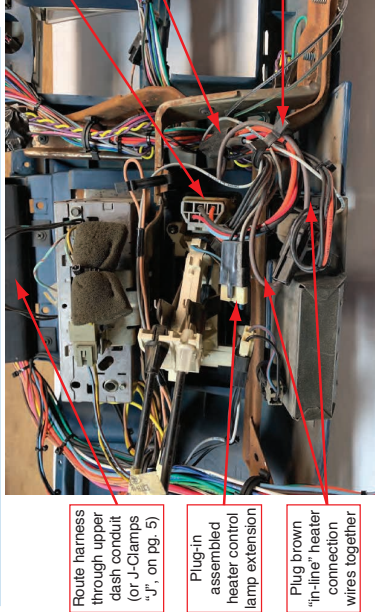

Route harness through upper dash conduit through upper dash conduit (or J-Clamps "J", on pg. 5)

Plug-in assembled heater control lamp extension

Plug brown "in-line" heater connection wires together

Plug-in heater control switch connector

Dash lamp candelabra

Route harness down through Clip "L" and over to the heater control

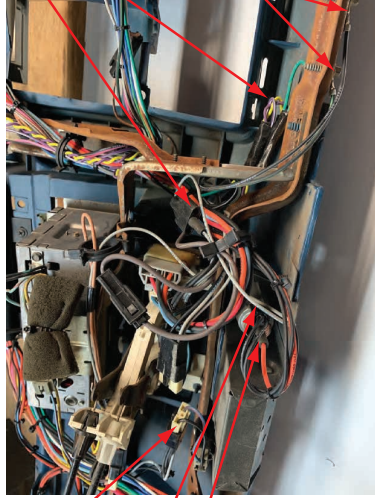

Plug-in assembled ashtray lamp extension

Plug-in the cigar lighter feed and ground connections

Attach ground wires for tach (black/green) and electric speedo (black/white) here. **Must use separate mounting screws**

9. Route the harness through the upper dash conduit. Route the harness down through routing clip "L", and build the heater lamp extension (see details for lamp extension on page 12). Plug-in the heater switch and lamp. Plug the "in-line" brown heater connection wires together if you do not have AC. The accessory dash lamp candelabra is also here in this area. See details on page 10.

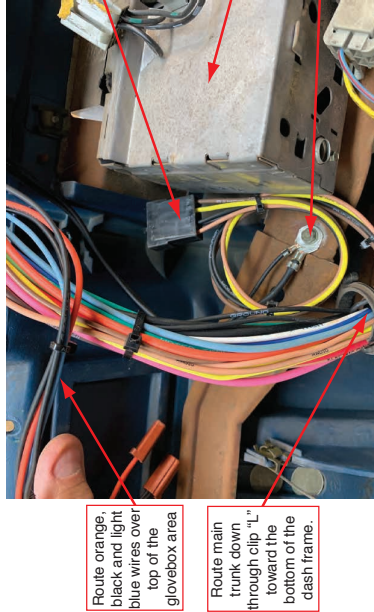

Route orange, black and light blue wires over top of the glovebox area

Route main trunk down through clip "L" toward the bottom of the dash frame.

Digital clock connection. See page 10 for detailed instructions

Radio Assembly

Attach ground wires here.

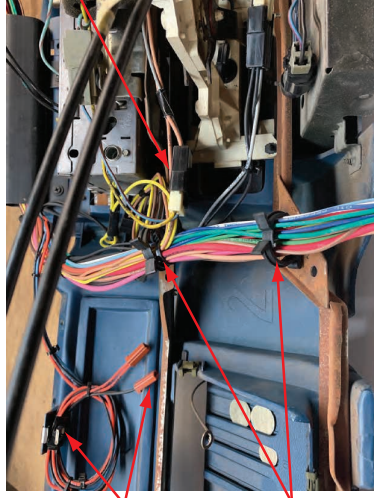

Route orange, black and light blue wires through the edge biter clip. Install orange and black wires onto glovebox light switch if so equipped.

Route main trunk down through clips "L" toward the bottom of the dash frame.

Radio and radio lamp connections. **(Terminals and connectors are not provided).**

11. Route the large trunk of the harness coming through the upper dash conduit down through clip "L". The orange, black and light blue wires will continue over top of the glovebox area. Attach the two black ground wires as shown above. Your digital clock connection is shown above also. See page 10 for detailed connection instructions.

Page 8

10. Plug in the cigar lighter feed and ground connections. Build and plug-in the ashtray lamp extension. See details for lamp extension on page 12. Plug any accessory dash lamp feeds (like radio backlight, aftermarket gauge backlights, etc.) into the candelabra. Attach the tach and electric speedo grounds as noted above right (**Mount separately**). Dash side VSS electric speedo lead (see page 12 for details).

12. Continue routing the main harness trunk down through clips "L" to the bottom of the dash frame. Make your radio and radio lamp connections. Route the orange, black and light blue wires through the edge biter clips "R" as shown above. Attach the orange and black wires to the glovebox lamp assembly (if so equipped).

Dash/Main harness installation instructions:

92972210 Rev 0.1 10/30/2019

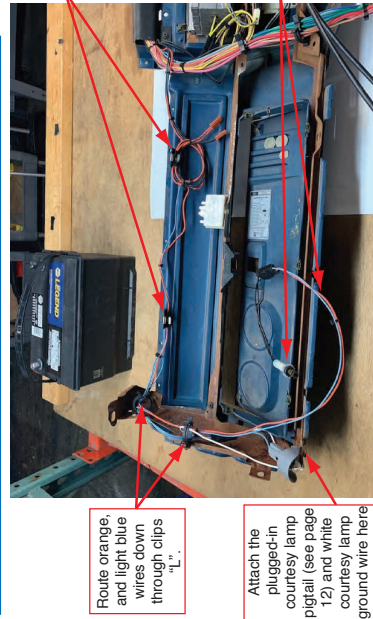

Route orange, and light blue wires down through clips "L".

Attach the plugged-in courtesy lamp digital (see page 12) and white courtesy lamp ground wire here

Route orange, black and light blue wires through the edge biter clips "R" as shown.

Drop the orange and light blue wires down through the kick panel into the doorjamb area. Install doorjamb switch into RH doorjamb.

Install dimmer switch 500042 onto harness. Will install into stock location.

Drop the orange and light blue wires down through the kick panel into the doorjamb area. Install doorjamb switch into LH doorjamb.

LH engine bay dash side connections. See pages 18-20 for details



Neutral Safety Switch (NSS) connection

Optional accessory power feed connector (See page 10)

Installed horn relay. See page 3 of these instructions

Turn signal, stop light and ignition switch leads. See pages 11-12 for details

Interior rear body connector. See pages 31-33 for details

14. This image shows the fuse box assembly, optional accessory power feed connector, horn relay, interior rear body connector, LH doorjamb switch assembly, dimmer switch lead and switch assembly, LH engine bay dash side connections, and the turn signal, ignition switch, NSS and stop light switch leads. These items will all install after you assemble the completed dash frame back into the vehicle.

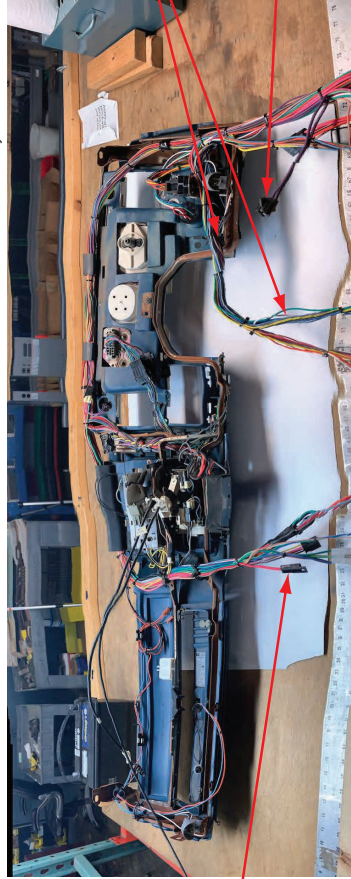

RH engine bay wire extensions will plug in here. See pages 21-23 for details

Route the turn signal, brake light and ignition switch leads through clip "L" as shown. See pages 11 and 12 for connection details

Neutral safety switch extension "V", NSS jumper "W", or stock clutch switch plug in here. See pages 5 and 10 for extension and connection details

15. Your new Dash Harness should look like the above photo once you have completed the installation. If your vehicle has any of the optional Factory A/C, Dual Fuel Tanks (F-Series), Rear Defroster (Bronco), or Rear Power Window (Bronco) Systems (these optional kits are shown on page 2), install that wiring now. See the installation instructions in each kit to complete those tasks. Install the completed Dash frame into the vehicle. Connect the Neutral Safety Switch Wiring (see page 10). Install the grommet on the LH Dash Side Engine Bay wiring, route everything through the Firewall, and seat the LH grommet (see page 19). Mount the Fuse Block and the Dimmer Switch. Install the Ignition (page 12), Turn Signal (modifications required see page 11), and Stop Light Switch (page 12) connectors. Connect the RH engine bay wiring (510728) and grommet onto the dash harness assembly, install those extensions through the firewall into the engine bay, and seat the RH grommet (see page 22).

Dash/Main harness installation instructions:

digital clock connection:

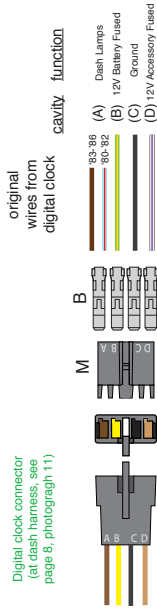

NOTE: Terminals and connector M and B are found in the 92972215 loose piece kit

dash light candleabra wiring:

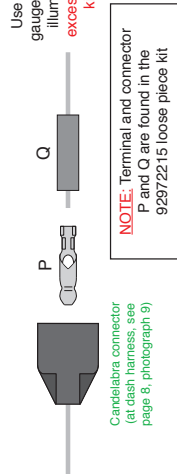

NOTE: Terminal and connector P and Q are found in the 92972215 loose piece kit

neutral safety switch (NSS) wiring (all years):

W/ MANUAL TRANSMISSION:

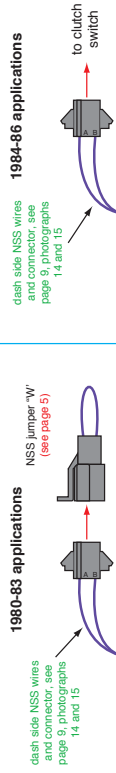

NOTE: Manual transmission equipped trucks did not utilize a NSS. The starter circuit on the '80-'83 trucks was wired directly from the ignition switch to the starter relay. For those vehicles, it will be necessary to plug the NSS jumper "W" (from page 5) onto the AAW dash harness NSS wires and connector in order for the truck to start. The starter circuit on the '84-'86 trucks was wired from the ignition switch through a clutch safety switch, then out to the starter relay. For those vehicles, it will be necessary to plug the AAW dash harness NSS wires and connector directly onto your factory clutch operated safety switch in order for the truck to start. (safety switch not included in this kit).

W/ AUTOMATIC TRANSMISSION:

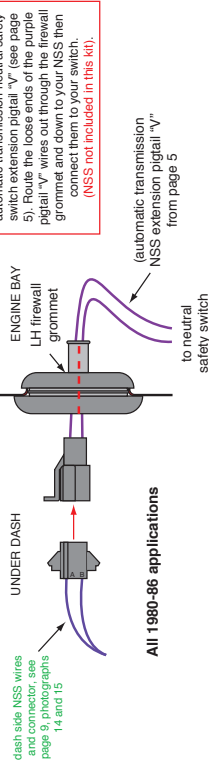

NOTE: If you have an automatic transmission, take the dash side NSS wires and connector, and connect to the automatic transmission neutral safety switch extension pigtail "Y" (see page 5). Route the loose ends of the purple pigtail "Y" wires out through the firewall grommet and down to your NSS then connect them to your switch. (NSS not included in this kit).

optional accessory power feed connector:

Use the provided 6-way empty connector, which is attached to the 6-way Accessory connector on the Dash Harness, and terminals "C" and "D" to add power wires for the following optional systems:

Wire Color	Wire Printing	Fuse Block Printing	Fuse Rating	Description
Orange	no printing	BAT3	15A	Fused 12 volt BATTERY feed spare (may also be used to feed power to another battery circuit)
Tan	FUEL PUMP	FUEL	20A	Fused 12 volt IGNITION feed for an electric fuel pump (may also be used to feed power to another battery circuit).
Orange	POWER SEATS	BAT2	30A	Fused 12 volt BATTERY feed for power seats (may also be used to feed power to another battery circuit).
Red	POWER LOCKS	BAT1	20A	Fused 12 volt BATTERY feed for power locks (may also be used to feed power to another battery circuit).
Pink	POWER WINDOWS	PWO WDO	30A	Fused 12 volt IGNITION feed for power windows (may also be used to feed power to another battery circuit).
Brown	IGNITION SW ACCY	ACCY1	30A	Fused 12 volt ACCESSORY feed for options.

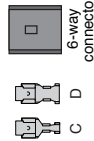

www.americanautowire.com 856-803-0801

510724 1980-86 Ford F-Series and Bronco Classic Update Series

[Dash/Main harness installation instructions:](#)
[turn signal switch wiring:](#)

“Table A”

AAW Turn Signal Switch wires to stock original 1980-86 (all) Ford Truck turn signal switch.

AAW Wire #	AAW Wire color	AAW Wire Printing	Connector Cavity	Ford Wire Color
17A,B	Blue & White	Brake Sw	P	Lt. Green.
19	Dark Green	Right Rear Turn	N	Orange with Lt. Blue stripe.
18	Yellow	Left Rear Turn	M	Lt. Green with Orange stripe.
16	Purple	Turn Switch Feed	L	Lt. Blue.
27	Brown	Turn Sw - Hazard	K	White with Red stripe.
15A,B	Dark Blue	Right Front Turn	J	White with Lt. Blue stripe.
14A,B	Light Blue	Left Front Turn	H	Lt. Green with White stripe.
28	Black	Horn Relay Ground	G	Yellow with Lt. Blue stripe.
150C	Black	Ground	F	Dk. Blue.
8B,C	Gray	Dash Lights	E	Lt. Blue with Red stripe.
N/A	N/A	N/A	D	N/A.

NOTE 1: If present, the black with pink stripe Ford wire is for the key buzzer, and the white with purple stripe Ford wire is for the cruise control. Neither of these wires are supported/used with this kit and should be taped back.

NOTE 2: Remove the original turn signal switch connector from your column by cutting it off. Strip each of the original steering column wires, crimp terminals "B" onto them, then plug them into connector "A" using "Table A," and "Diagram A," on this page as a guide. Items "A," and "B" (from page 5), can be found in the dash loose piece kit (92972215).

NOTE 3: Wires indicated as having a "stripe" on them, may have a stripe, hashes or dots, to indicate the secondary color.

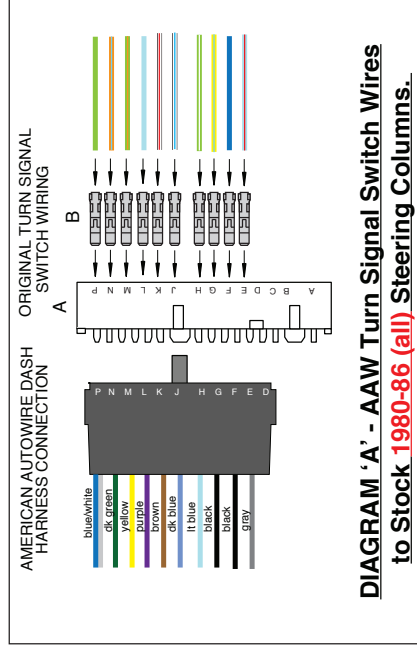

DIAGRAM 'A' - AAW Turn Signal Switch Wires to Stock 1980-86 (all) Steering Columns.



www.americanautowire.com 856-933-0801

510724 1980-86 Ford

F-Series and Bronco

Classic Update Series

92972210 Rev 0.1 10/30/2019

Dash/Main harness installation instructions: building the dash lamp extension assemblies:

The lamp sockets on the AC / heater control, headlight and wiper switch, ashtray and (optional) rear defroster dash illumination lamps are not available, and must be re-used. They all have the same light blue/red stripe and a black wire going into the sockets. You will need to cut the original Ford connectors off of each of these lamp extensions, strip the wires, and from page 5, crimp on terminal "B" then plug the wires into connector "N" as shown below. These completed pigtails will plug into your new AAV dash harness as shown on pages 7 and 8. If you have a Bronco with the rear defroster option, instructions creating and plugging-in that connection are found in that optional kit, 510485.

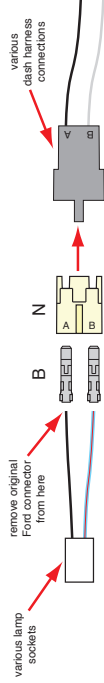

assembling the courtesy lamp extensions:

Install one courtesy lamp extension "T" on each of the LH and RH courtesy lamp connections of the dash harness. These completed lamp assemblies will mount to the bottom of the dash frame assembly in the locations shown on pages 7 (photo #7) and 9 (photo #13). Attach the white ground wire under the same screw that you use to mount the courtesy lamp (screws not included).

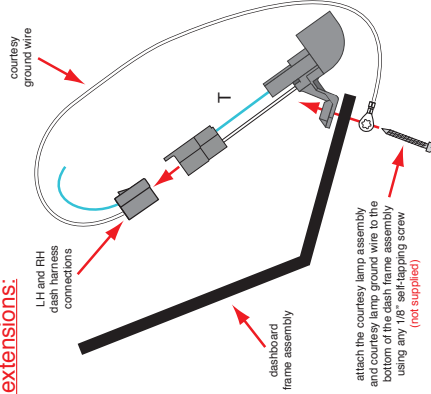

attach the courtesy lamp assembly and courtesy lamp ground wire to the bottom of the dash frame assembly using any 1/8" self-tapping screw (not supplied)

**510724 1980-86 Ford
F-Series and Bronco
Classic Update Series**

Page 12 92972210 Rev 0.1 10/30/2019



www.americanautowire.com 855-833-0801

ignition switch connector and wiring:

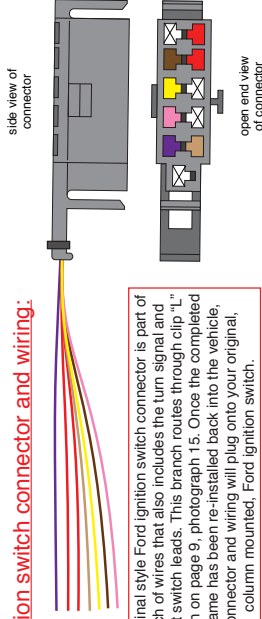

This original style Ford ignition switch connector is part of a branch of wires that also includes the turn signal and ignition switch stop light switch leads. This branch routes through clip "L" as shown on page 9, photograph 15. Once the completed dash frame has been re-installed back into the vehicle, this connector and wiring will plug onto your original, column mounted, Ford ignition switch.

stop light switch connector and wiring:

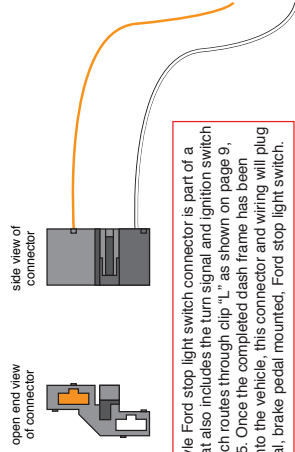

This original style Ford stop light switch connector is part of a branch of wires that also includes the turn signal and ignition switch leads. This branch routes through clip "L" as shown on page 9, photograph 15. Once the completed dash frame has been re-installed back into the vehicle, this connector and wiring will plug onto your original, brake pedal mounted, Ford stop light switch.

electric speedo VSS extension connection:

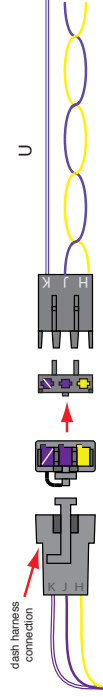

If you are using an aftermarket electric speedometer in your vehicle, you will need to connect the vehicle speed sensor extension pigtail "U" to the dash side connection (see page 8, photograph 10) on your dash harness. The yellow and solid purple wires must remain twisted together as shown above on "U". These three wires will need to pass out into the engine bay through the RH firewall grommet down to the transmission. Generally, the solid purple wire connects to the "Signal" lead, the yellow wire connects to the "ground" lead, and the purple/white stripe wire connects to the "12 volt power" lead on the vehicle speed sensor assembly, but you should connect per the manufacturer's instructions.

Gauge Cluster harness installation instructions:

USE THIS SHEET TO CONNECT TO AN ORIGINAL 1980 FORD TRUCK STANDARD INSTRUMENT CLUSTER WITH FUEL AND TEMP GAUGES ONLY

14-WAY CIRCUIT BOARD CONNECTOR

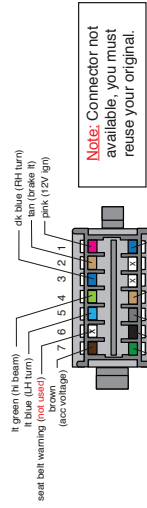

Note: Connector not available, you must reuse your original.

tech "out" to negative coil (CUSTOM APPLICATION ONLY)

NOTE: This AAW kit does not support the use of a factory ammeter, alternator warning lamp, or seat belt warning lamp. AAW suggests using a voltmeter to monitor the charging system of your vehicle.

- There were 4 different stock dash cluster configurations used on the 1980-86 Ford trucks. Specific instructions for the different years and applications follow on pages 13 through 16 of this instruction set. Please choose the one that applies to your truck to complete your installation.
- You will need to re-use your original dash cluster connector, as it is not available. We have provided new terminals "G" for you to crimp onto the wires of the new cluster harness (510726). These terminals will plug into your original stock dash cluster connector.
- If you are using an aftermarket cluster or gauges, please refer to page 17 for detailed instructions for your installation. Terminal kit 92965220 has been provided to complete most any aftermarket gauge panel installation.

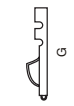
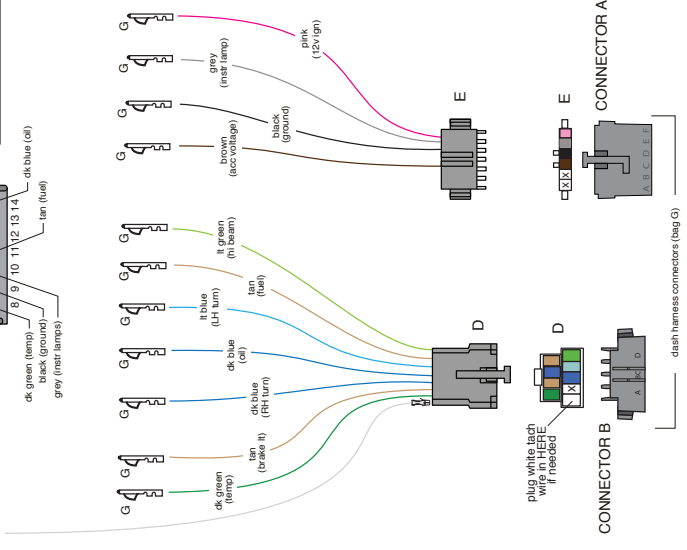

American Autowire
www.americanautowire.com 855-853-0801
510724 1980-86 Ford F-Series and Bronco Classic Update Series
92972210 Rev 0.1 10/30/2019

**Gauge Cluster harness
installation instructions:**

USE THIS SHEET TO CONNECT TO AN ORIGINAL 1980 FORD TRUCK OPTIONAL INSTRUMENT CLUSTER WITH FUEL, TEMP AND OIL GAUGES WITH or W/O OPTIONAL TACH (ammeter and seat belt warning not supported).

18-WAY CIRCUIT BOARD CONNECTOR

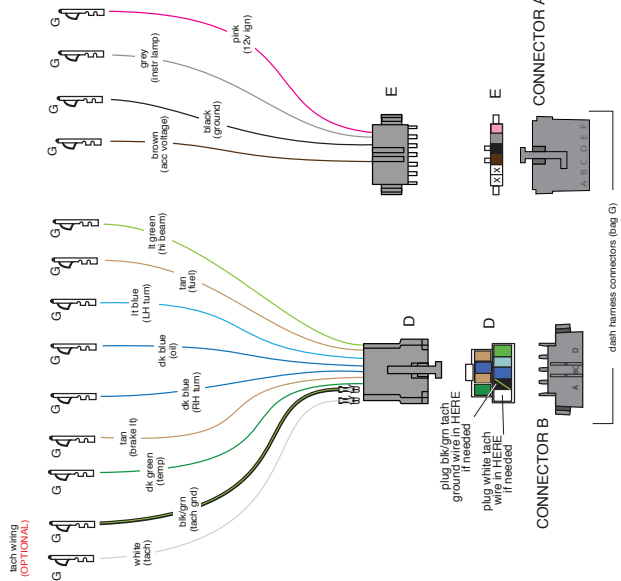
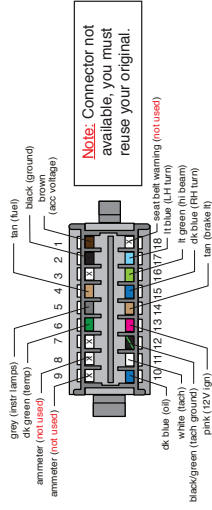

American Autowire
 www.americanautowire.com 866-933-0901
510724 1980-86 Ford
F-Series and Bronco
 Classic Update Series
 92972210 Rev 0.1 10/30/2019

Gauge Cluster harness installation instructions:

USE THIS SHEET TO CONNECT TO AN ORIGINAL 1981-86 FORD TRUCK STANDARD INSTRUMENT CLUSTER WITH FUEL AND TEMP GAUGES ONLY

14-WAY CIRCUIT BOARD CONNECTOR

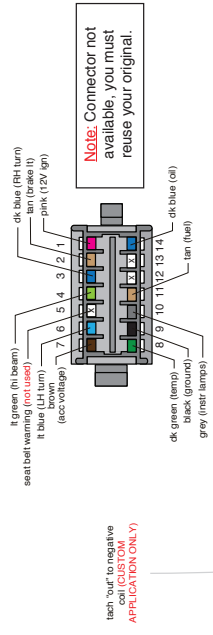

Note: Connector not available, you must reuse your original.

tech "out" to negative coil (CUSTOM APPLICATION ONLY)

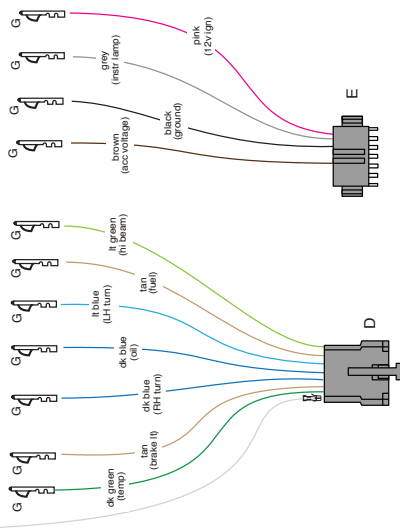

plug white, each wire in separate if needed



American Autowire
www.americanautowire.com 856-933-0801

510724 1980-86 Ford F-Series and Bronco Classic Update Series
92972210 Rev 0.1 10/30/2019

**Gauge Cluster harness
installation instructions:**

USE THIS SHEET TO CONNECT TO AN ORIGINAL 1981-86 FORD TRUCK OPTIONAL INSTRUMENT CLUSTER WITH FUEL, TEMP AND OIL GAUGES WITH or W/O OPTIONAL TACH (ammeter and seat belt warning not supported)

18-WAY CIRCUIT BOARD CONNECTOR

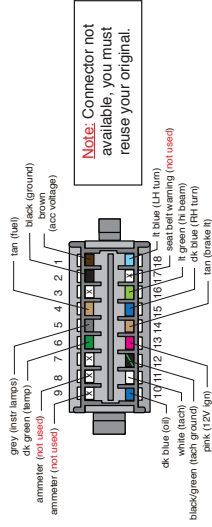

Note: Connector not available, you must reuse your original.

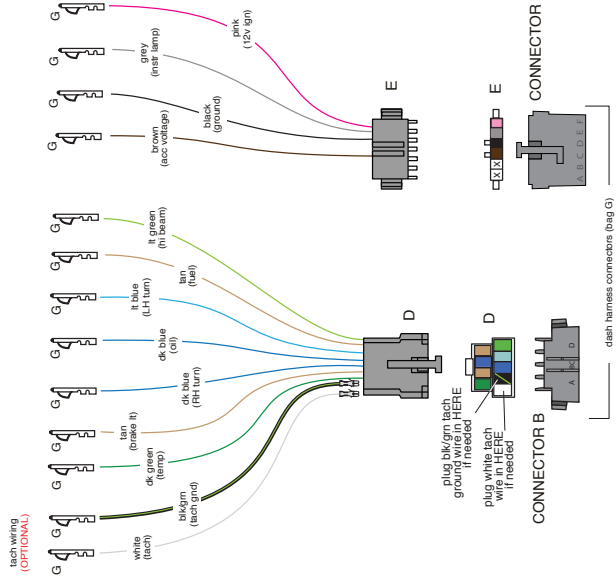

Gauge Cluster harness installation instructions:

SHOWN BELOW IS A TYPICAL **AFTERMARKET GAUGE** INSTALLATION PROCEDURE. FOLLOW THE MANUFACTURER'S INSTRUCTIONS FOR BEST RESULTS.

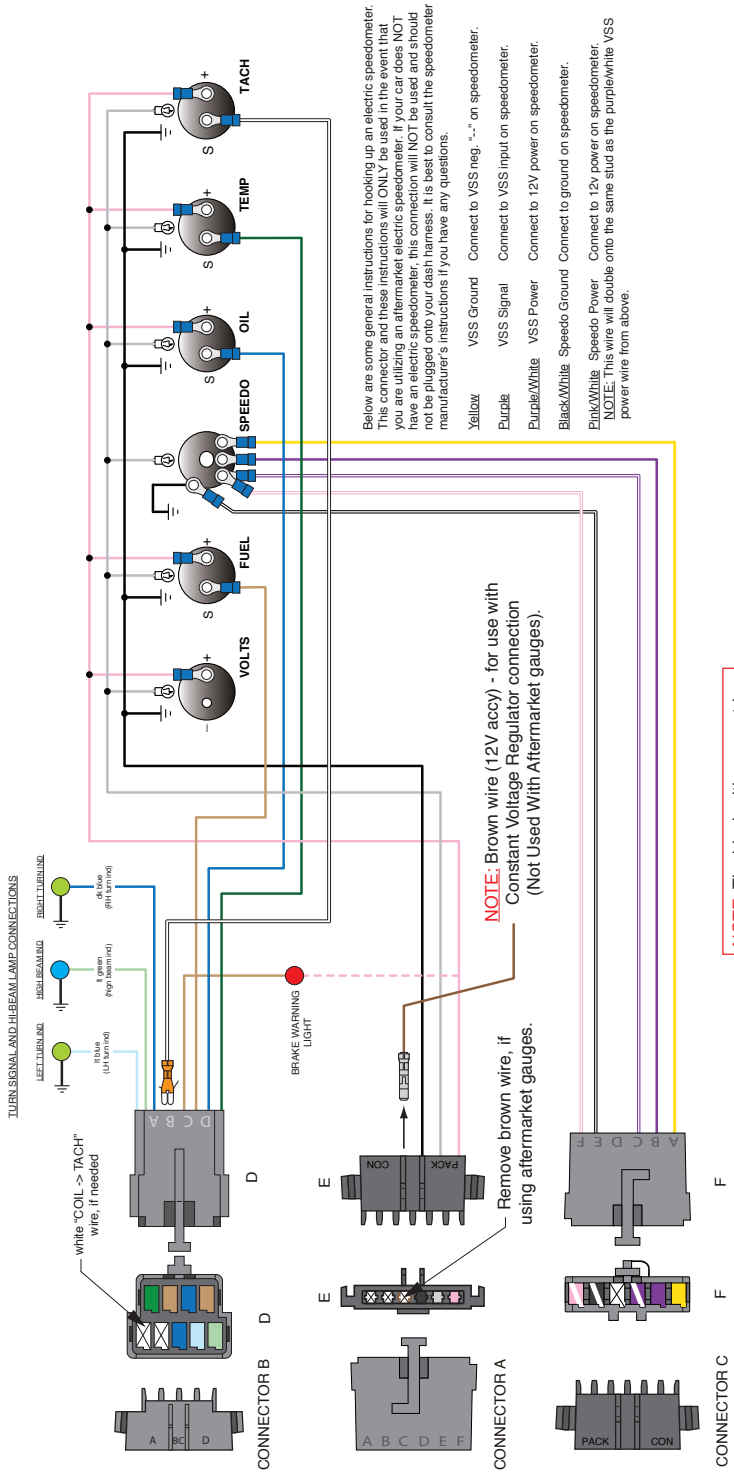

Below are some general instructions for hooking up an electric speedometer. This connector and these instructions will ONLY be used in the event that you are utilizing an aftermarket electric speedometer. If your car does NOT have an electric speedometer, this connection will NOT be used and should not be plugged into your dash harness. It is best to consult the speedometer manufacturer's instructions if you have any questions.

- Yellow VSS Ground Connect to VSS neg. "-" on speedometer.
- Purple VSS Signal Connect to VSS input on speedometer.
- Purple/White VSS Power Connect to 12V power on speedometer.
- Black/White Speedo Ground Connect to ground on speedometer.
- Pink/White Speedo Power Connect to 12V power on speedometer.
- NOTE: This wire will double onto the same stud as the purple/white VSS power wire from above.

American Autowire
 Classic Update Series
 510724 1980-86 Ford F-Series and Bronco
 www.americanautowire.com 856-933-9801
 92972210 Rev 0.1 10/30/2019

[510727 LH engine bay installation instructions:](#)

Below are the supplied harness extensions, terminals, connector bodies and assorted components included in the LH Engine Bay Harness and Loose Piece bags. These will be used to complete your LH engine bay connections and are referred by the letters and descriptions below from this point forward.

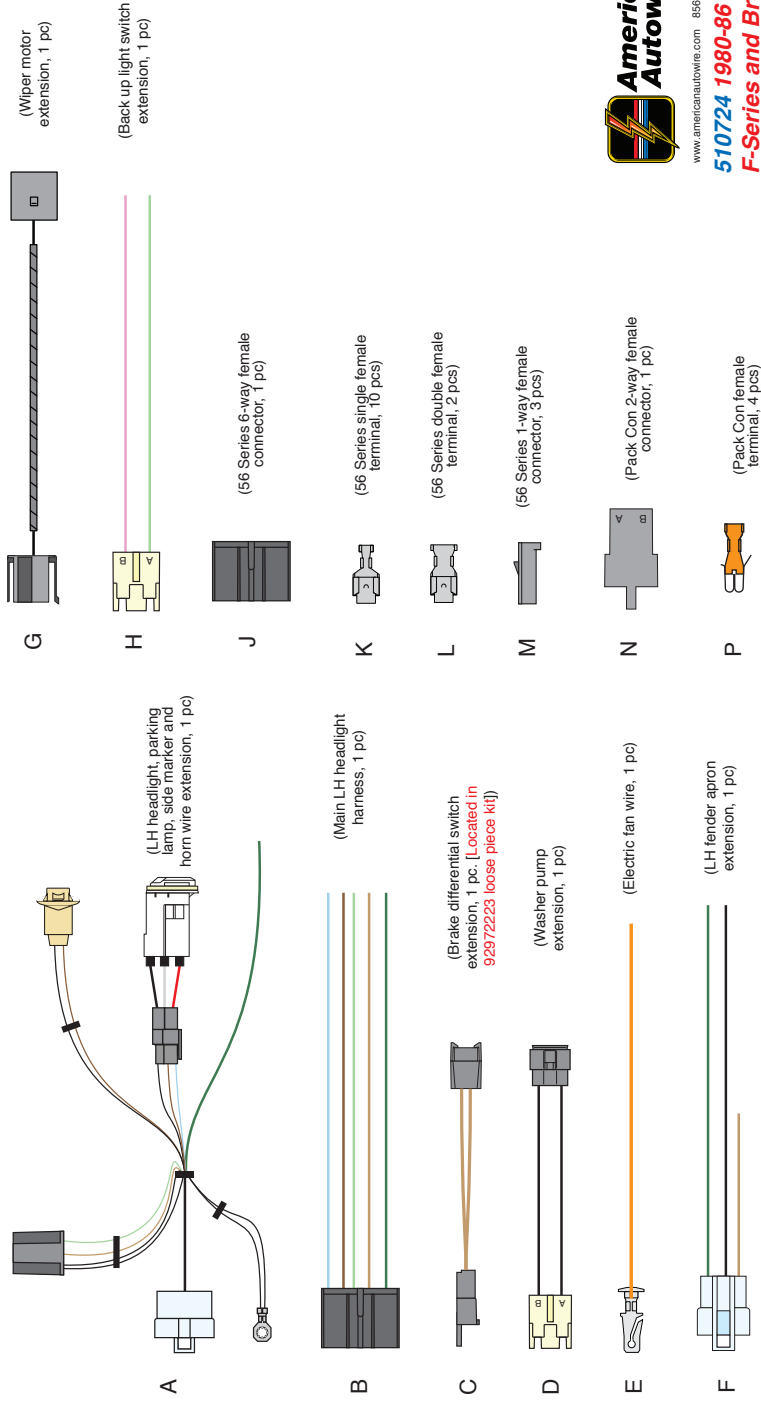

www.americanautowire.com 856-933-0801

510724 1980-86 Ford F-Series and Bronco Classic Update Series

92972210 Rev 0.1 10/30/2019

LH engine bay installation instruction details:

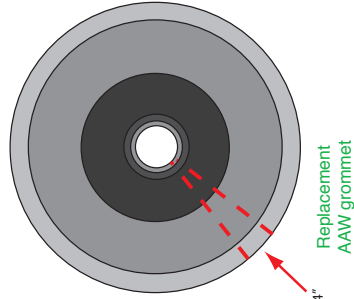
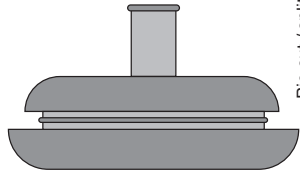
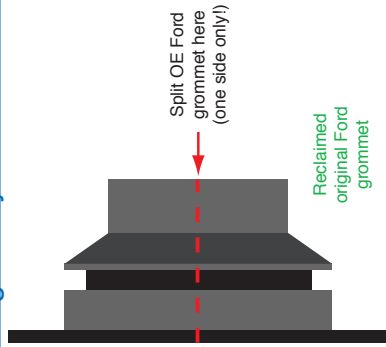

- NOTE:** Before you route your Dash Harness through the Firewall, follow these instructions:
1. We recommend that you re-use your original Ford Grommet that is located on the LH branch of your original Instrument Panel Wiring Harness and was seated in the Firewall. Split your grommet by cutting it on one side only, remove it from the original harness and fit it over the new Dash Harness Wiring as shown below.
 2. If your original grommet is not salvageable, we have provided a new grommet (see item "E" on page 5). This grommet can be found in the Loose Piece Kit in the Dash Harness Bag 510725. You will have to split and pie cut this new grommet as shown here. Attach it to the Dash Harness Wiring as shown below.
 3. Once the grommet is installed, route all of the wiring through the firewall opening and seat the grommet in the firewall. Details regarding the final assembly of the wires included in the LH Engine Bay Harness (510727) are shown on page 20.

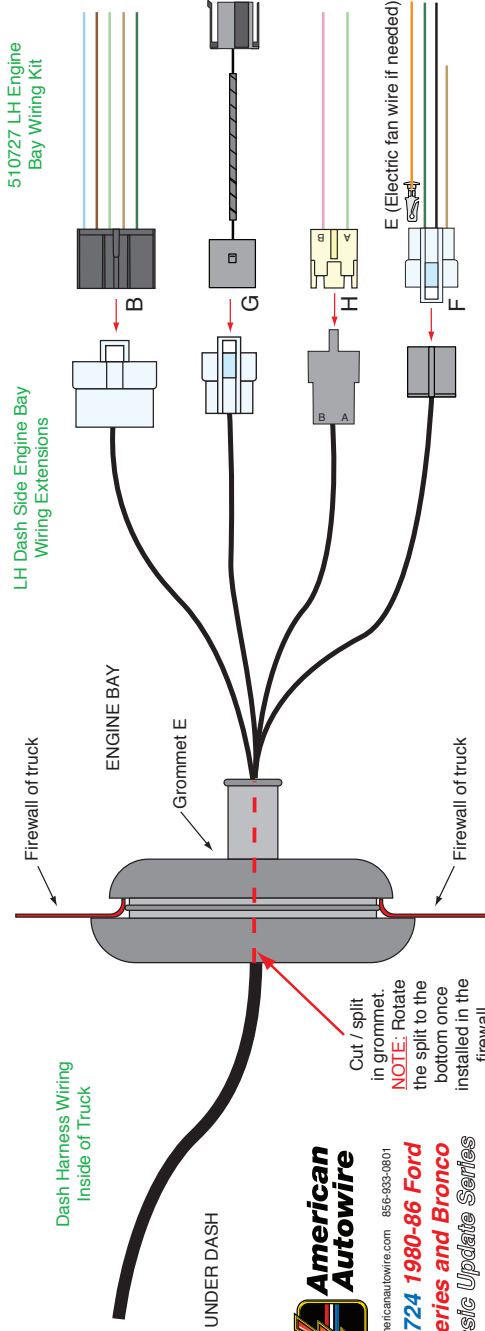

American Autowire
 www.americanautowire.com 856-933-0801
510724 1980-86 Ford F-Series and Bronco Classic Update Series
 92972210 Rev 0.1 10/30/2019

LH engine bay installation instructions:

wiper motor wiring plug:

Wiper motor extension harness G from page 18

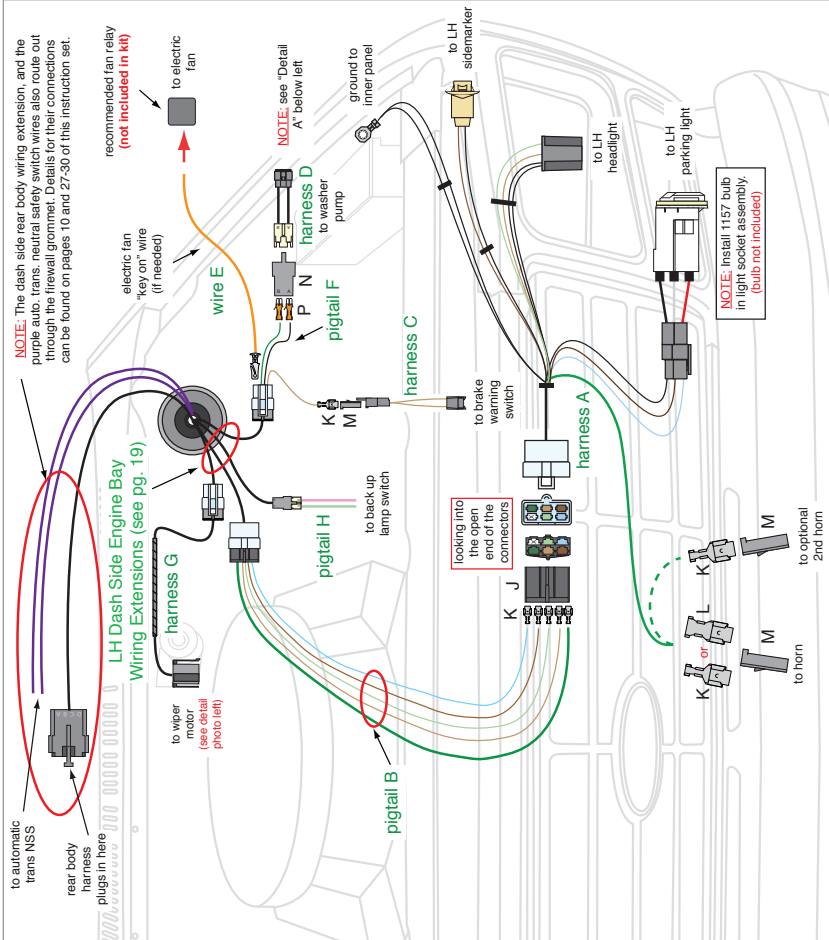
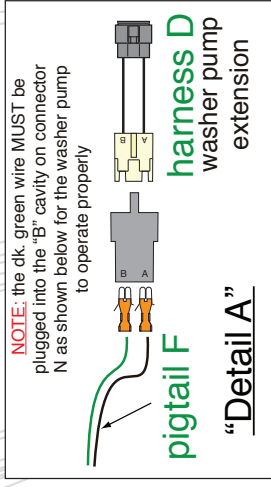
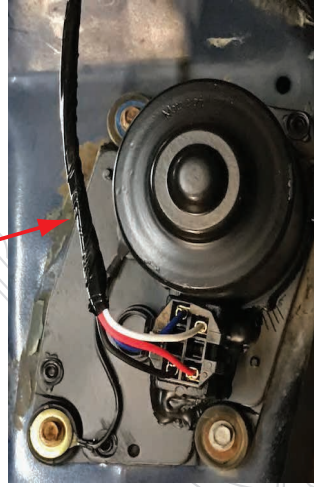

510728 RH engine bay installation instructions:

Below are the supplied misc. harness extensions, terminals, connector bodies and assorted components included in the RH Engine Bay Harness and Loose Piece bags. These will be used to complete your RH engine bay connections and are referred by the letters and descriptions below from this point forward.

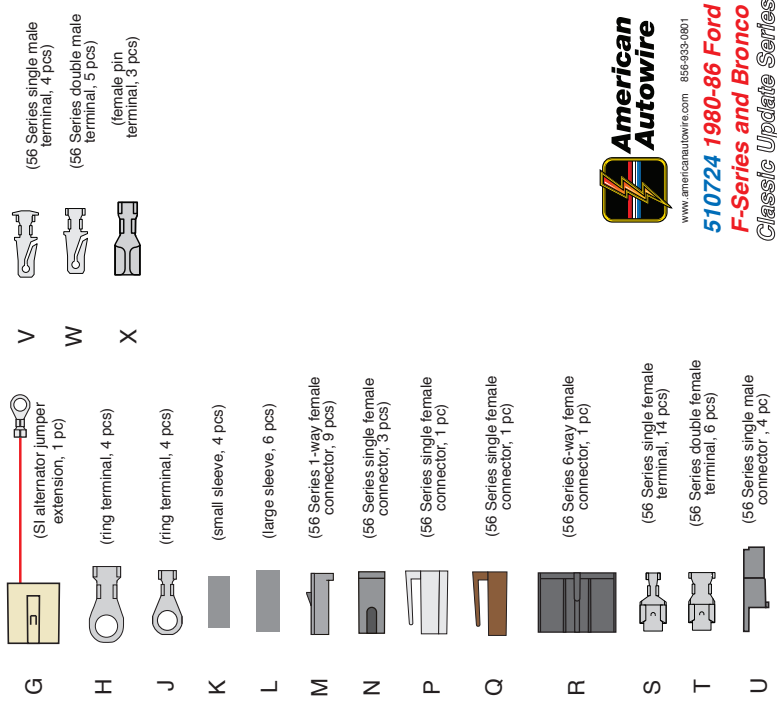
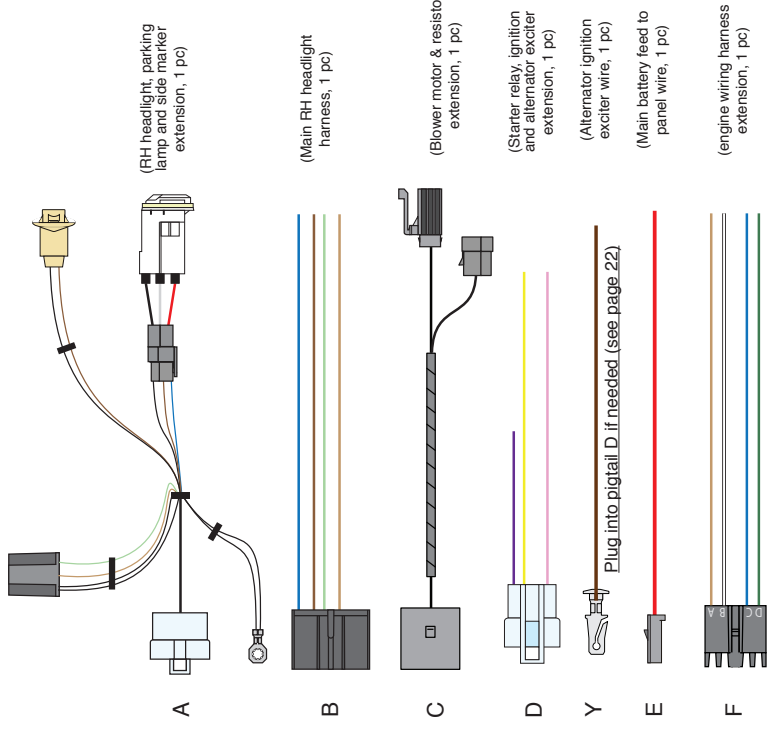



 www.americanautowire.com 856-933-0871

510724 1980-86 Ford

F-Series and Bronco

Classic Update Series

 92972210 Rev 0.1 10/30/2019

RH engine bay installation instruction details:

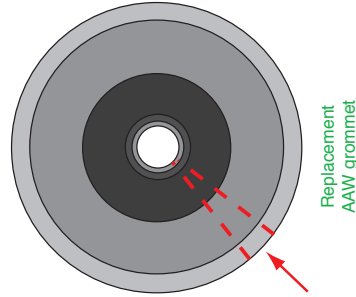
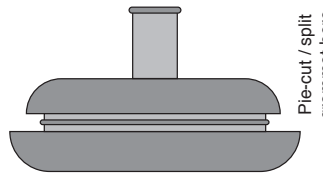
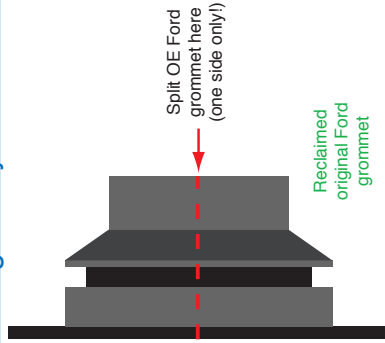

NOTE: Before you route your Dash Harness through the Firewall, follow these instructions:

1. We recommend that you re-use your original Ford Grommet that is located on the RH branch of your original Instrument Panel Wiring Harness and was seated in the Firewall. Split your grommet by cutting it on one side only, remove it from the original harness and fit it over the new RH Engine Bay Harness (510728) as shown below.
2. If your original grommet is not salvageable, we have provided a new grommet (see item "E", on page 5). This grommet can be found in the Loose Piece Kit in the Dash Harness Bag 510725. You will have to split and pie cut this new grommet as shown here. Attach it to the RH Engine Bay Harness (510728) as shown below.
3. With the grommet installed on the RH Engine Bay Wiring, route it through the firewall opening and seat the grommet into the firewall. Plug the Dash Side Engine Bay Extension Wiring into the RH Engine Bay Wiring. Details regarding the final assembly of the wires included in the RH Engine Bay Wiring (510728) are shown on page 23.

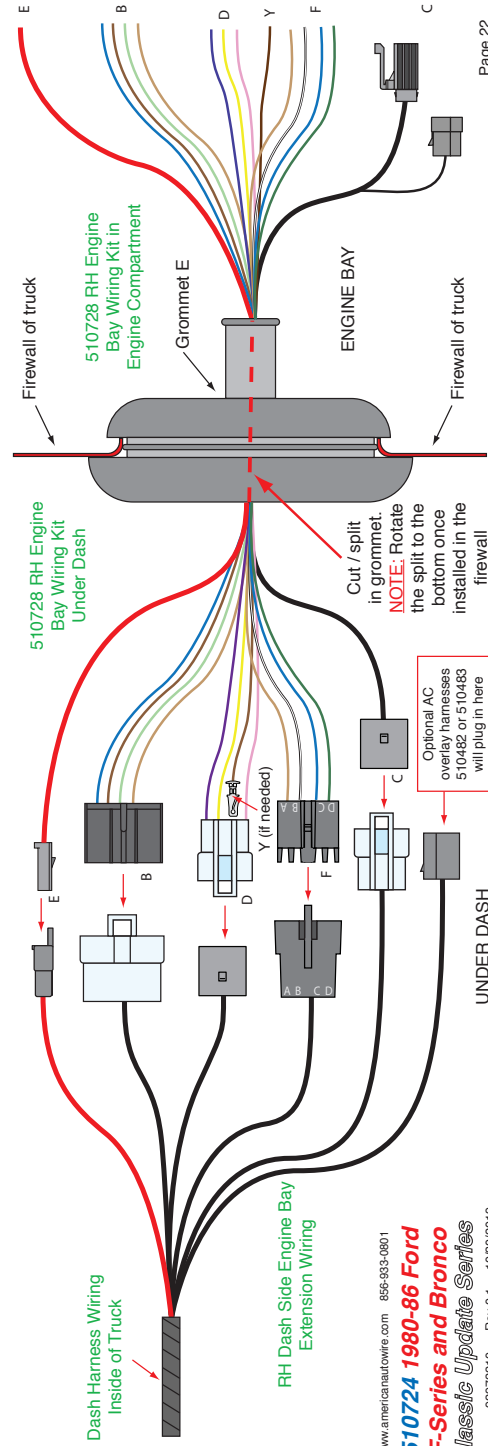

Engine harness installation instructions:
Generic Ford Dura-Spark Ignition system wiring:

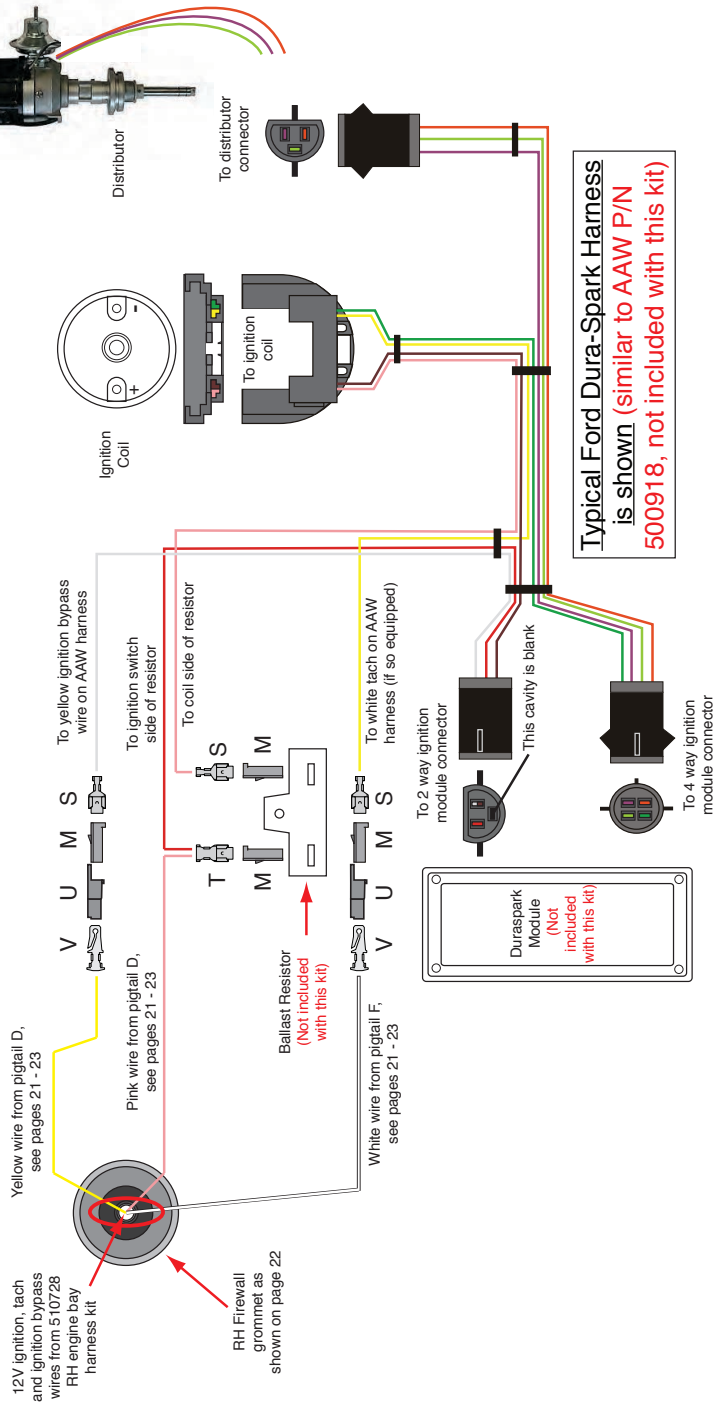

Typical Ford Dura-Spark Harness is shown (similar to AAW P/N 500918, not included with this kit)

510724 1980-86 Ford
 F-Series and Bronco
 Classic Update Series



www.americanautowire.com 866-933-0901

92972210 Rev 0.1 10/30/2019

[Engine harness installation instructions:](#)

[HEI Type Ignition system wiring:](#)

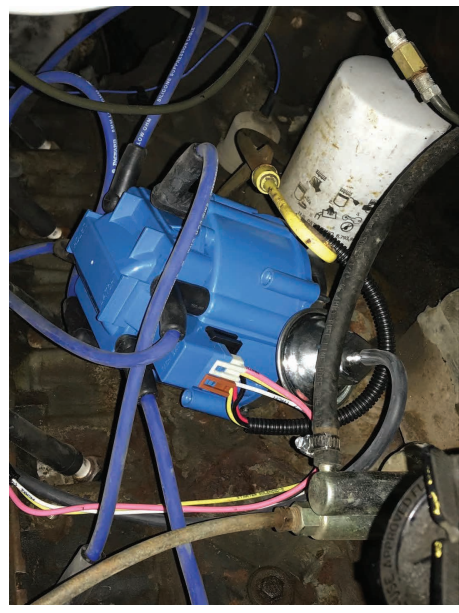
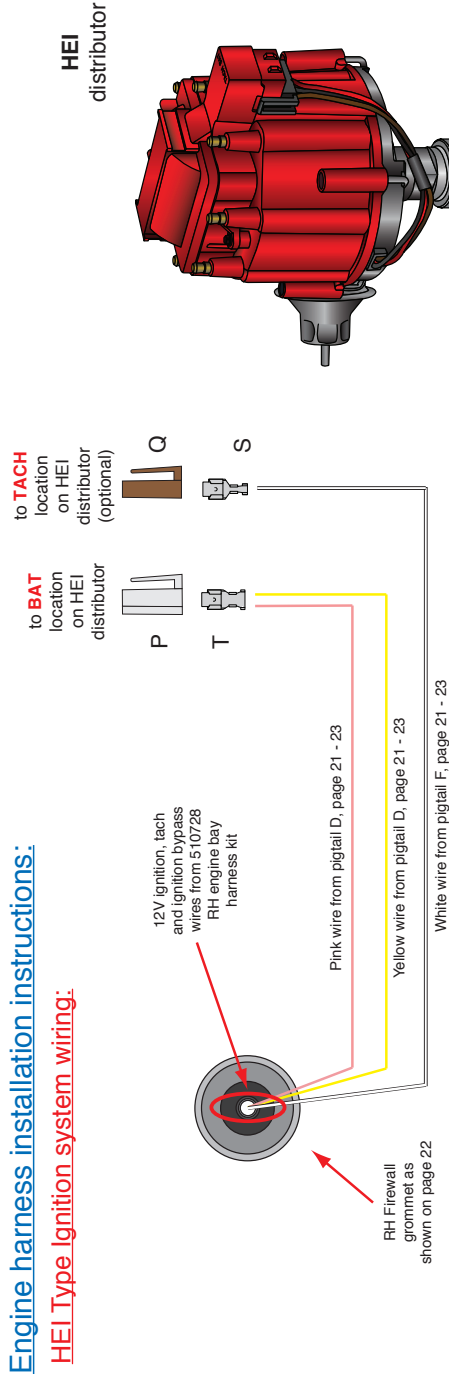



















510724 1980-86 Ford
F-Series and Bronco
Classic Update Series
92972210 Rev 0.1 10/30/2019



510729 Rear Body harness installation instructions:

Below are the supplied terminals, connector bodies and assorted components included in the 510729 Rear Body Harness and Loose Piece bags. These will be used to complete your Rear Body Harness exterior and interior connections as shown on pages 27 - 33, and are referred by the letters and descriptions below from this point forward.

 <p>(LH tail lamp harness, 1 pc) (RH tail lamp harness, 1 pc)</p>	 <p>(80 - '84 Fuel gauge Sender Jumper, 1pc)</p>	 <p>(85 - '86 Fuel gauge Sender Jumper, 1 pc)</p>	 <p>(License light Jumper, 2 pcs)</p>	 <p>(Ground wire, 1 pc)</p>	 <p>(56 Series 4-way female connector, 2 pcs)</p>	 <p>(56 Series single male connector, 1 pc)</p>	 <p>(56 Series single female connector, 1 pc)</p>	 <p>(56 Series single female terminal, 10 pcs)</p>	 <p>(56 Series double female terminal, 6 pcs)</p>	 <p>(Pack-Con 2-way female connector, 3 pcs)</p>	 <p>(Pack-Con single female terminal, 7 pcs)</p>	 <p>(Pack-Con double female terminal, 4 pcs)</p>	 <p>(female pin terminal, 8 pcs)</p>	 <p>(large rubber sleeve, 8 pcs)</p>	 <p>(male bullet terminal, 8 pcs)</p>	 <p>(small rubber sleeve, 8 pcs)</p>	 <p>(56 Series single male terminal, 12 pcs)</p>	<p>(56 Series double male terminal, 2 pcs)</p>	<p>(Bronco rear courtesy light connector, 1 pc)</p>	<p>(Standard Ford box terminal, 5 pcs)</p>	<p>(56 Series 4-way male connector, 2 pcs)</p>
--	---	--	--	---	--	--	--	---	--	---	---	---	---	---	--	---	---	--	---	--	--



www.americanautowire.com 856-933-0801

**510724 1980-86 Ford
F-Series and Bronco
Classic Update Series**

92972210 Rev 0.1 10/30/2019

Styleside and Bronco

Rear Body

harness

installation

instructions

w step bumper:

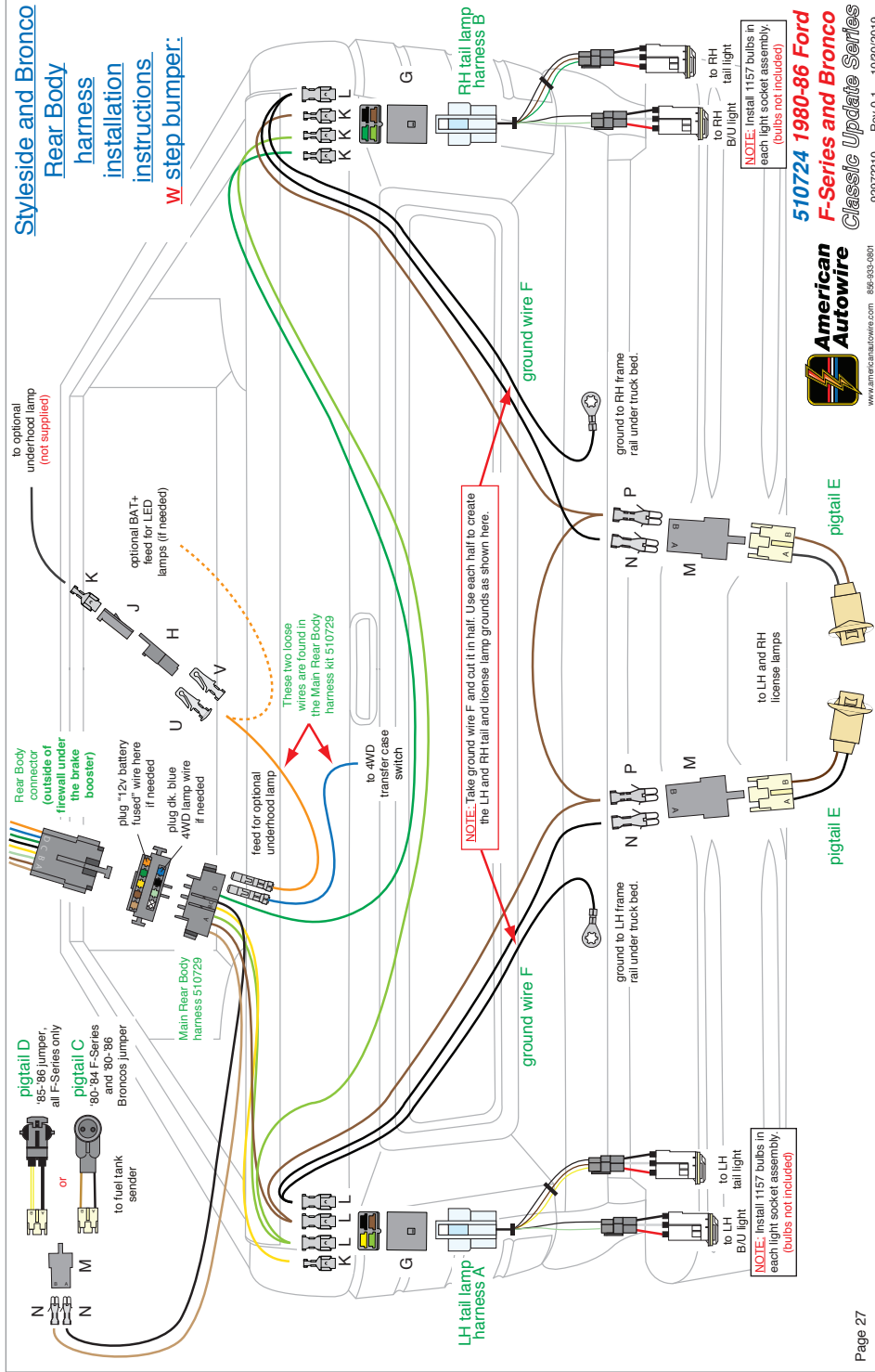

510724 1980-86 Ford
F-Series and Bronco
Classic Update Series

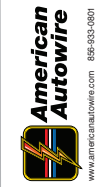

www.americanautowire.com 856-833-0801

92872210 Rev 0.1 10/30/2019

Styleside and Bronco

Rear Body harness installation instructions w/o step bumper:

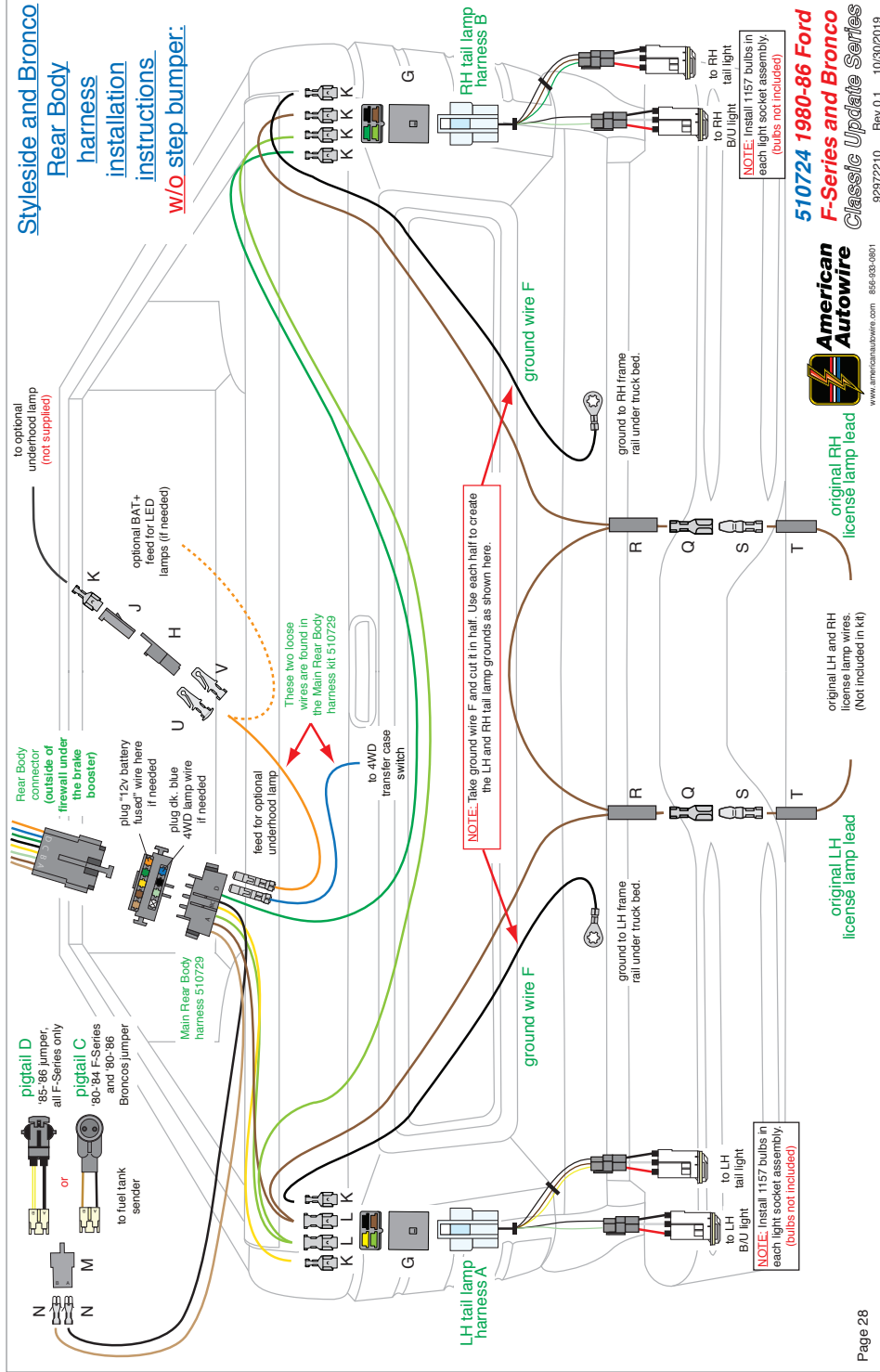

510724 1980-86 Ford F-Series and Bronco Classic Update Series



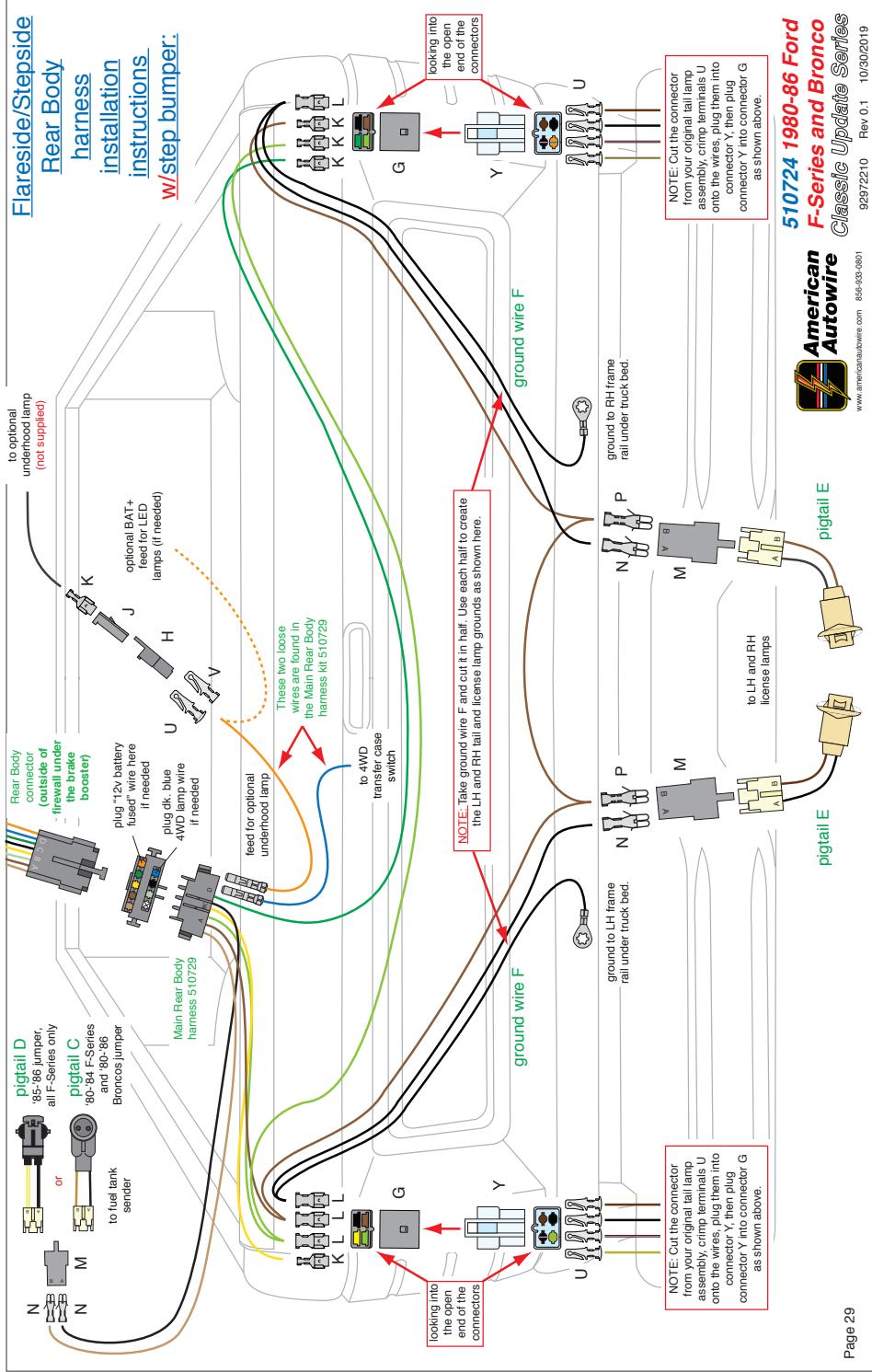

Flareside/Stepside Rear Body harness installation instructions w/step bumper.

510724 1980-86 Ford F-Series and Bronco Classic Update Series



www.americanautowire.com 855-352-3501

92972210 Rev 0.1 10/30/2019

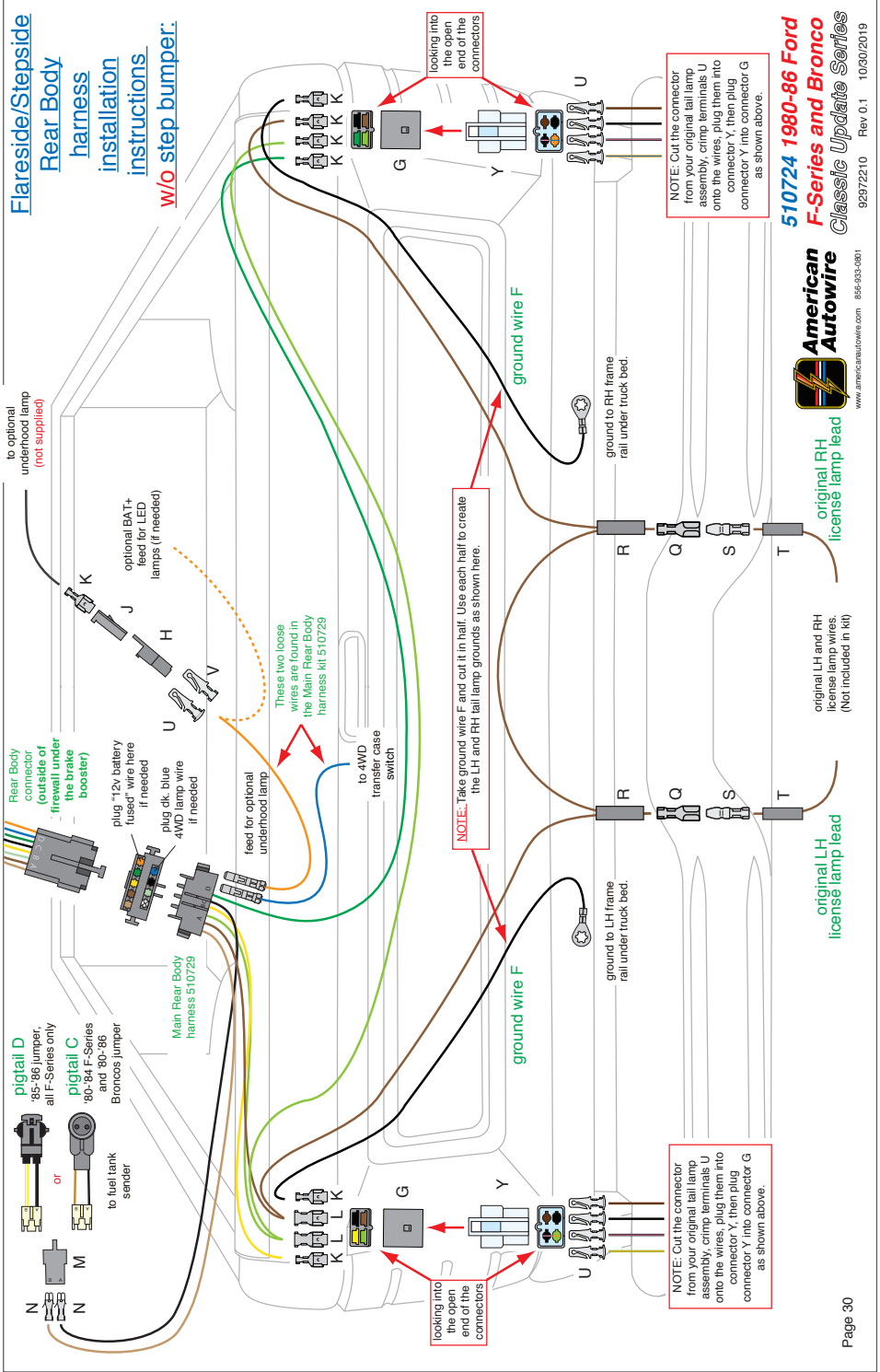

510724 1980-86 Ford
F-Series and Bronco
 Classic Update Series



92972210 Rev. 0.1 10/30/2019

Use this page for all F-Series Trucks and all Broncos without a rear compartment courtesy light.

Installation Instructions:

NOTE: The factory dome and/or map light assemblies are self grounding units that do not require the use of a separate ground wire. You MUST re-use your original (or a replacement) dome/map light assembly and its lead wires as they use a very unique terminal that is part of the assembly. We have provided terminals and sleeves "Q, R, S and T" to make these connections.

1. The interior rear body harness can be found in the 510729 Rear Body Harness kit. It consists of a single lt. blue wire (12v ctsy sw) plugged into a 4-way black connector along with 3 loose coiled wires (orange 12v battery fused, light blue "third brake", black "ground"). All trucks utilized an overhead dome light. If your truck has the optional map light, or you are adding an aftermarket third brake light, you will need to install the optional coiled wires into the empty cavities of the 4-way connector as shown below on this page.
2. The interior rear body harness connector will plug onto the dash harness in the LH Kick panel area (see page 9, photo 14) of your truck. Route the wires along the LH rocker sill area to the LH rear cab corner.
3. Make your connections between the new harness and the original dome/map lamp assembly down in that area.

Main connection to dash harness

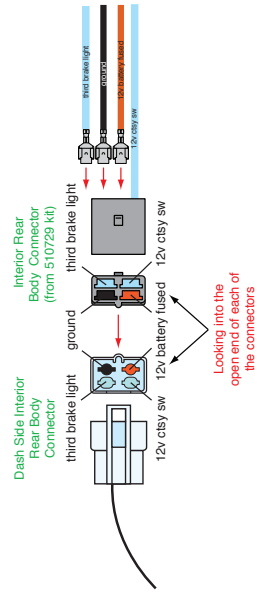

Interior Rear Body harness installation instructions: (dome, map, & 3rd brake light)

Dome light only application

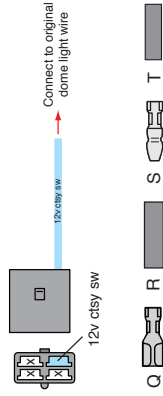

Dome/map light application

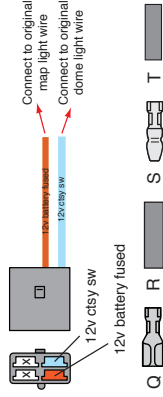

Dome/map, third brake light application

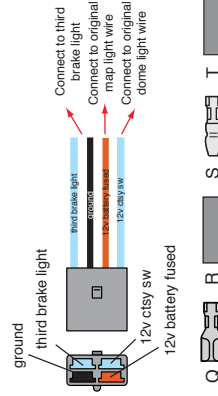

Dome/third brake light application

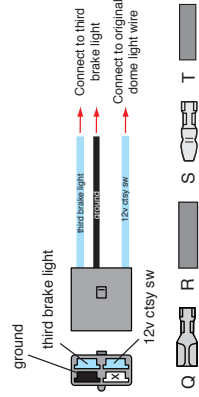

Use the next two pages for all Broncos with a rear compartment courtesy light.

Installation Instructions:

NOTE: The factory dome and/or map light assemblies are self grounding units that do not require the use of a separate ground wire. You MUST re-use your original (or a replacement) dome/map light assembly, and its lead wires as they use a very unique terminal that is part of the assembly. We have provided terminals and sleeves "Q, R, S and T" to make these connections.

1. The interior rear body harness can be found in the 510729 Rear Body Harness kit. It consists of a single lt. blue wire (12v ctsy sw) plugged into a 4-way black connector along with 3 loose coiled wires (orange 12v battery fused, light blue "third brake", black "ground"). In this application, all trucks utilized an overhead dome light along with the rear courtesy light, so you will need to install the orange and black wires. If you are adding an aftermarket third brake light, you will need to install the optional light blue wire as well. All wires will plug into the empty cavities of the 4-way connector as shown below on this page.
2. The interior rear body harness connector will plug onto the dash harness in the LH kick panel area (see page 9, photo 14) of your truck. Route the wires along the LH rocker sill area back into the rear cargo area.
3. You will make the connections to the original rear courtesy light first. Choose the proper assembly instructions for your application from pages 32 and 33. Route the wires to your rear courtesy light and cut them. In several instances, you will use the cut off portion to double back to the dome/map or third brake lights. Crimp terminals X onto the wires, plug the completed wires into connector W, then plug the completed connector W into the rear courtesy lamp assembly.
4. Next, take any wires that you doubled off of the rear courtesy connections, bring them over to the overhead dome light (orange 12v battery fused and lt. blue 12v ctsy sw) or optional third brake light (lt. blue third brake light and black ground) and connect them as necessary as shown on pages 32 or 33.

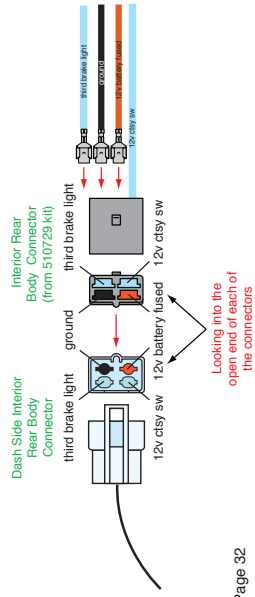

Interior Rear Body harness installation instructions: (dome, map, & 3rd brake light)

Dome and rear courtesy application

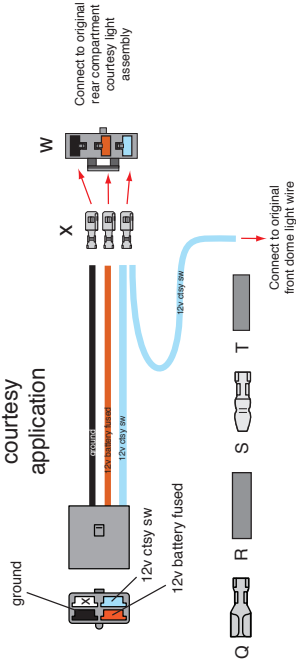

Dome/map and rear courtesy application

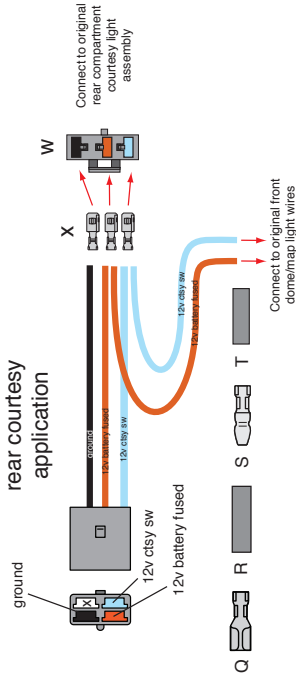

510724 1980-86 Ford F-Series and Bronco Classic Update Series



www.americanautowire.com 855-933-9601

92972210 Rev 0.1 10/30/2019

Interior Rear Body harness installation instructions:
([dome_map_ & 3rd brake light](#))

Dome, rear courtesy, and third brake light application

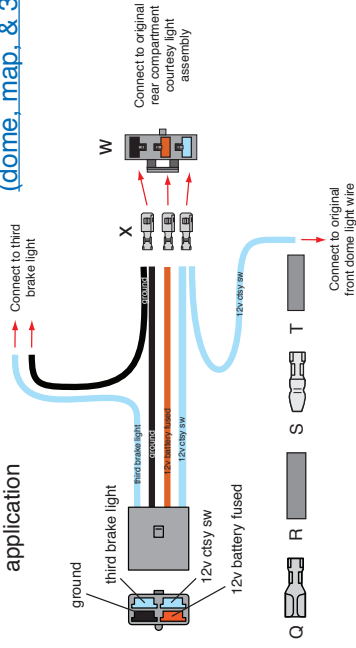

Dome/map, rear courtesy, and third brake light application

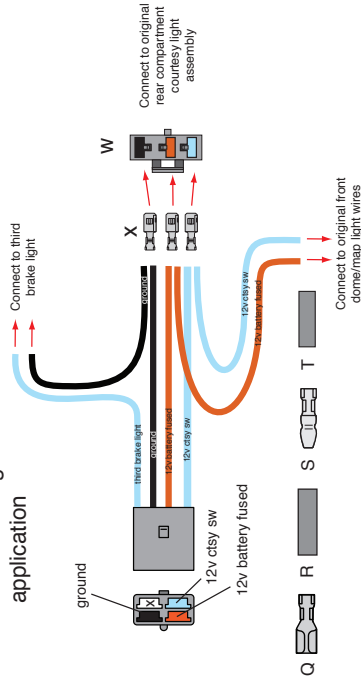

STEP 8: RECONNECT YOUR BATTERY:

When you have completed the installation and are ready to reconnect the battery, make sure that the following electrical system grounds are in place:

- A. Battery is grounded to the ENGINE BLOCK.
- B. Battery is grounded to the frame.
- C. Engine block is grounded to the frame.
- D. Body is grounded to the frame.

If you have any questions concerning this or any of our products, please feel free to call us at 1-856-933-0801.

THIS PAGE HAS INTENTIONALLY
BEEN LEFT BLANK

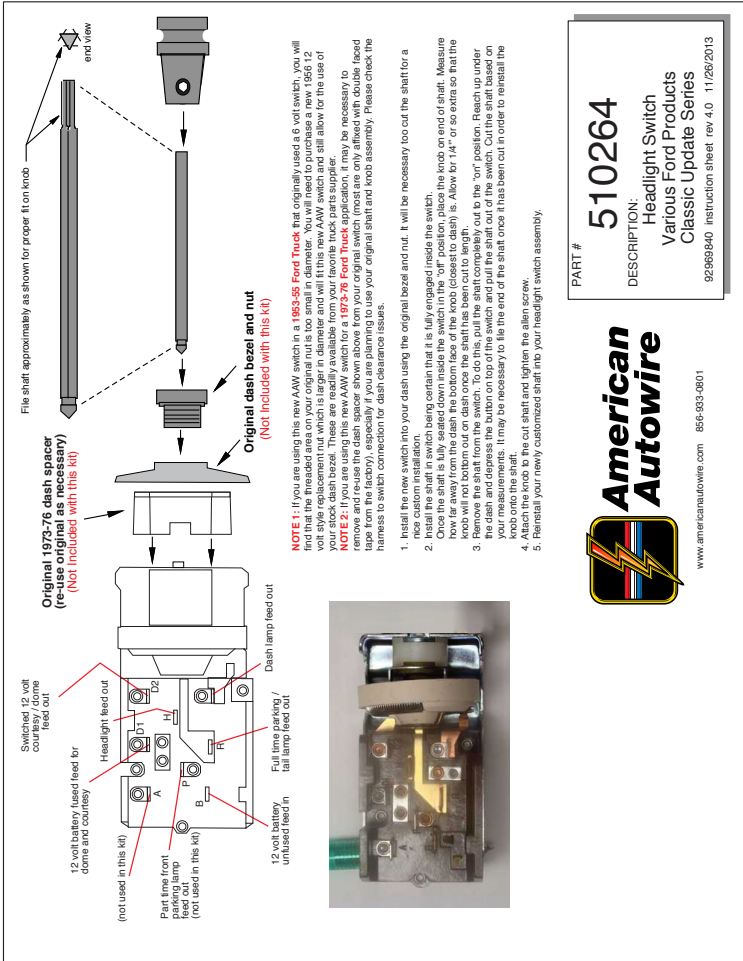

www.americanautowire.com 866-853-8801

PART #
510264
DESCRIPTION:
 Headlight Switch
 Various Ford Products
 Classic Update Series
 92369840 instruction sheet rev 4.0 11/26/2013