

INSTRUCTION SHEET

MOTORCRAFT CARBURETOR - MODEL 2150

(ANEROID ASSY. USED ON SOME MODELS)

50-619

GENERAL EXPLODED VIEW

THE GENERAL DESIGN AND PARTS WILL VARY TO INDIVIDUAL UNITS COVERED ON THIS INSTRUCTION SHEET.

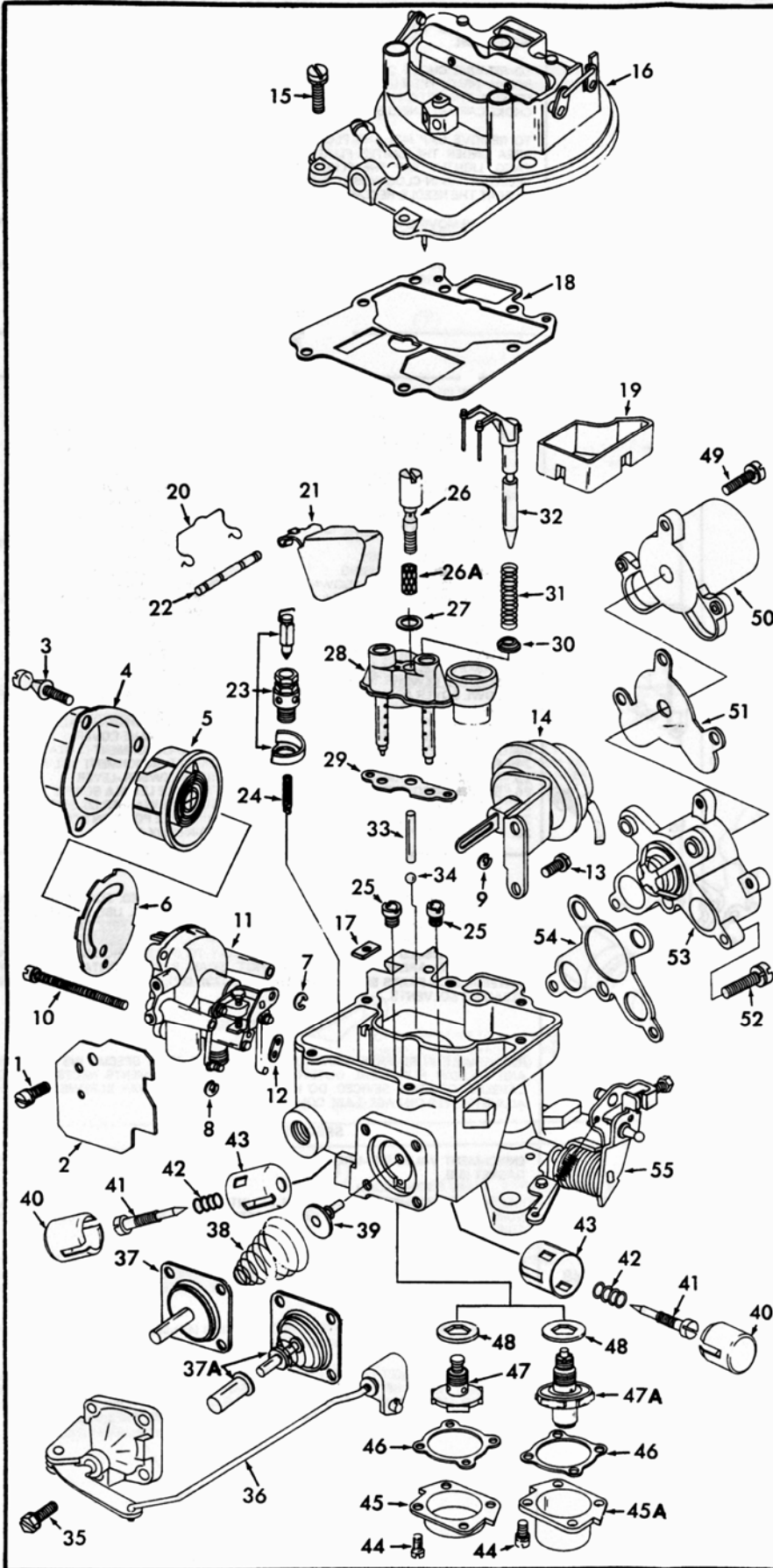

DISASSEMBLY

USE EXPLODED VIEW AS A GUIDE. THE NUMERICAL SEQUENCE MAY GENERALLY BE FOLLOWED TO DISASSEMBLE UNIT FAR ENOUGH TO PERMIT CLEANING AND INSPECTION. NOTE: NOT ALL MODELS WILL BE EQUIPPED WITH A FUEL BOWL SPACER OR WITH THE ANEROID ASSY. MODELS WILL ALSO DIFFER FROM A SINGLE STAGE TO A (TWO) STAGE ENRICHMENT VALVE.

TO REMOVE CHOKE COVER CLAMP TAMPER PROOF SCREWS, CENTER PUNCH THE SCREW HEAD, THEN USING A 1/4" DRILL, DRILL THE SCREW HEAD DEEP ENOUGH TO REMOVE THE RETAINING RING AND CAP. REMOVE THE REMAINING PORTION OF THE CHOKE CAP RETAINING SCREWS WITH A LOCKING PLIERS.

TO REMOVE CAP (40) AND PLUG (43) FROM IDLE MIXTURE NEEDLE, SUPPORT THE AREA UNDER THE LIMITER PLUG AND USING A POINTED TOOL DIRECTED AT THE TANG, LIGHTLY TAP THE PLUG FORWARD. BEFORE REMOVING IDLE ADJUSTING NEEDLE, TURN IN CLOCKWISE COUNTING THE NUMBER OF TURNS IT TAKES TO LIGHTLY SEAT THE NEEDLE. RECORD FOR REASSEMBLY.

NOMENCLATURE

REF NO.	REF. NO.
1. SCREW—AIR SHIELD	31. SPRING— AIR METERING ROD
2. AIR SHIELD	32. AIR METERING ROD ASSY.
3. SCREW (3)—CHOKE COVER CLAMP	33. WEIGHT —PUMP DISC. BALL
4. CLAMP—CHOKE COVER	34. BALL—PUMP DISC.
5. CHOKE COVER & SPRING ASSY.	35. SCREW (4)—PUMP DIAPHRAGM COVER ASSY.
6. GASKET—CHOKE COVER	36. COVER, LEVER & ROD ASSY.—PUMP
7. RETAINER— CHOKE ROD	37. PUMP DIAPHRAGM ASSY.
8. RETAINER— FAST IDLE CAM ROD (LOWER)	37A. PUMP DIAPHRAGM ASSY. F.I.O.D.
9. RETAINER—CHOKE PULLDOWN ROD	38. SPRING - PUMP DIAPHRAGM RETURN
10. SCREW & LKWSHR. (3)—CHOKE HOUSING	39. VALVE - PUMP INLET CHECK
11. CHOKE HOUSING ASSY.	40. CAP (2) - IDLE LIMITER
12. GASKET—CHOKE HOUSING	41. NEEDLE (2) - IDLE ADJUSTING
13. SCREW (2)—CHOKE PULLDOWN ASSY.	42. SPRING (2) - IDLE ADJUSTING
14. CHOKE PULLDOWN MOTOR & HOSE ASSY.	43. NEEDLE PLUG (2) - IDLE LIMITER
15. SCREW & LKWSHR. (6)—BOWL COVER	44. SCREW & LKWSHR. (4) ENRICHMENT VALVE COVER
16. BOWL COVER ASSY.	45. COVER - ENRICHMENT VALVE
17. SEAL—CHOKE ROD	45A. COVER - ENRICHMENT VALVE (2 STAGE)
18. GASKET—BOWL COVER	46. GASKET - ENRICHMENT VALVE COVER
19. SPACER—FUEL BOWL (USED WITH SHORT FLOAT.)	47. VALVE - ENRICHMENT
20. RETAINER—FLOAT PIN	47A. VALVE - ENRICHMENT (2 STAGE)
21. FLOAT & LEVER ASSY.	48. GASKET - ENRICHMENT VALVE
22. PIN—FLOAT LEVER	49. SCREW & LKWSHR. (3) ANEROID ASSY.
23. NEEDLE & SEAT, BAFFLE ASSY.	50. ANEROID ASSY.
24. SCREEN —NEEDLE SEAT	51. GASKET - ANEROID ASSY.
25. JETS (2) —MAIN METERING	52. SCREW & LKWSHR. (4) - POPPET VALVE ASSY.
26. SCREW — PUMP DISCHARGE NOZZLE	53. POPPET VALVE ASSY. - ALT.
26A. SCREEN—PUMP NOZZLE SCREW	54. GASKET - POPPET VALVE HOUSING
27. GASKET—NOZZLE SCREW	55. MAIN BODY ASSY.
28. VENTURI CLUSTER ASSY.	
29. GASKET—VENTURI CLUSTER	
30. RETAINER —AIR METERING ROD SPRING	

CLEANING

CLEANING MUST BE DONE WITH CARBURETOR DISASSEMBLED. SOAK PARTS LONG ENOUGH TO SOFTEN AND REMOVE ALL FOREIGN MATERIAL. USE A CARBURETOR CLEANING SOLVENT. MAKE CERTAIN THE THROTTLE BORES ARE FREE OF ALL CARBON AND VARNISH DEPOSITS. RINSE OFF IN SUITABLE SOLVENT. BLOW OUT ALL PASSAGES IN CASTINGS WITH COMPRESSED AIR AND CHECK CAREFULLY TO INSURE THOROUGH CLEANING OF OBSCURE AREAS. CAUTION: DO NOT SOAK PARTS CONTAINING RUBBER MATERIALS OR PARTS SUCH AS (6), (14), (21), (37), (47), (50), AND (53) IN CLEANING SOLVENTS.

REASSEMBLY

REASSEMBLE IN REVERSE ORDER OF DISASSEMBLY. NOTE SPECIAL INSTRUCTIONS AND FOLLOW NUMERICAL OUTLINE IN MAKING ADJUSTMENTS NECESSARY FOR CARBURETOR BEING SERVICED. DO NOT TIGHTEN BREAK—AWAY SCREWS UNTIL THE ADJUSTMENTS ON PAGE 2 ARE COMPLETED.

SPECIAL INSTRUCTIONS

ENRICHMENT VALVE (47)—USE CARE WHEN TIGHTENING TO PREVENT DISTORTION OF GASKET (48).

IDLE ADJUSTING NEEDLES (41)—TURN IN UNTIL LIGHTLY SEATED, THEN BACK OUT NUMBER OF TURNS RECORDED ON DISASSEMBLY. (DO NOT INSTALL CAPS (40) AT THIS TIME.)

PUMP INLET CHECK VALVE INSTALLATION (39)—LUBRICATE TIP OF NEW VALVE AND INSERT IN CENTER HOLE OF PUMP CAVITY. USE A NEEDLE NOSE PLIERS AND PULL THROUGH FROM FUEL BOWL SIDE UNTIL FULLY SEATED. CUT OFF VALVE TIP AT RETAINING SHOULDER.

PUMP DIAPHRAGM RETURN SPRING INSTALLATION (38)—INSTALL LARGE OPEN END OF SPRING OVER RUBBER INLET CHECK VALVE (39)

BOWL COVER GASKET (18)—THIS TUNE-UP KIT MAY NOT CONTAIN THE FLOAT BOWL GASKET OF THE CONFIGURATION SHOWN UNDER REF. NO. 18, OR BE IDENTICAL TO THE GASKET REMOVED FROM THE CARBURETOR. TO ENSURE PROPER OPERATION USE THE D9AE-9561-CA GASKET IN THE TUNE-UP KIT FOR THE D9AE-9561-BB OR D9TE-9561-BA GASKET FOUND IN CARBURETOR. PART NUMBERS ARE STAMPED ON GASKETS.

INSTRUCTION SHEET

MOTORCRAFT CARBURETOR-MODEL 2150A

WITH FEEDBACK CONTROL

GENERAL EXPLODED VIEW

THE GENERAL DESIGN AND PARTS SHOWN WILL VARY TO INDIVIDUAL UNITS COVERED ON THIS INSTRUCTION SHEET

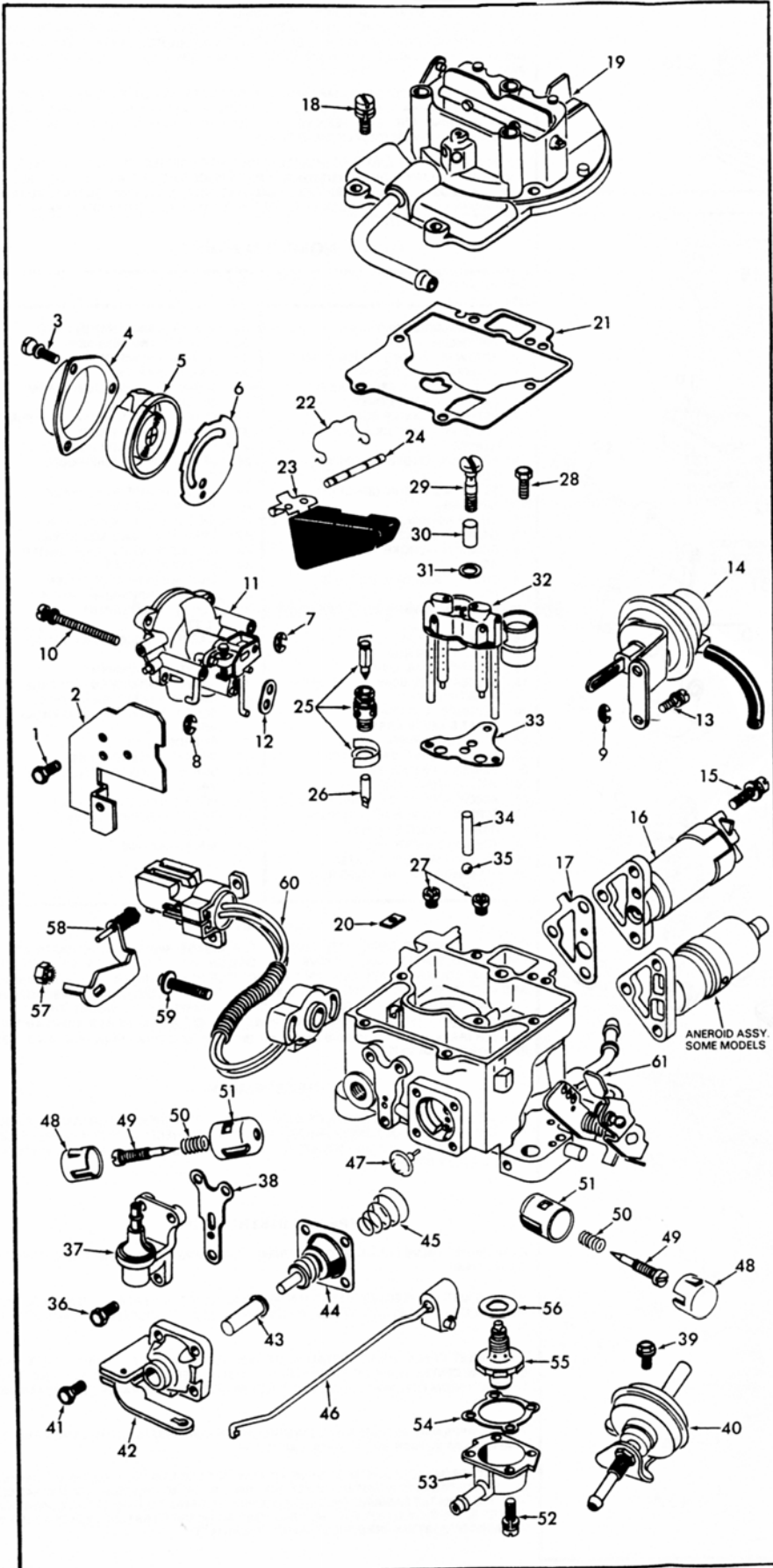

DISASSEMBLY

USE THE EXPLODED VIEW AS A GUIDE. THE NUMERICAL SEQUENCE MAY GENERALLY BE FOLLOWED TO DISASSEMBLE UNIT FAR ENOUGH TO PERMIT CLEANING AND INSPECTION.

TO REMOVE CHOKE COVER CLAMP TAMPER PROOF SCREWS. CENTER PUNCH THE SCREW HEAD. THEN USING A 1/4" DRILL, DRILL THE SCREW HEAD DEEP ENOUGH TO REMOVE THE RETAINING RING AND CAP. REMOVE THE REMAINING PORTION OF THE CHOKE CAP RETAINING SCREWS WITH A LOCKING PLIERS.

TO REMOVE CAP (48) AND PLUG (51) FROM IDLE MIXTURE NEEDLE, SUPPORT THE AREA UNDER THE LIMITER PLUG AND USING A POINTED TOOL DIRECTED AT THE TANG, LIGHTLY TAP THE PLUG FORWARD. BEFORE REMOVING IDLE ADJUSTING NEEDLE, TURN IN CLOCKWISE COUNTING THE NUMBER OF TURNS IT TAKES TO LIGHTLY SEAT THE NEEDLE. RECORD FOR REASSEMBLY.

BEFORE REMOVING PUMP ROD ASSY. (46) MARK LOCATION OF ROD IN PUMP THROTTLE LEVER.

BEFORE REMOVING THROTTLE POSITION SENSOR (60) SCRIBE TWO MARKS ON SENSOR AND THROTTLE BODY FOR PROPER REASSEMBLY.

NOMENCLATURE

REF. NO.	REF. NO.
1. SCREW (3)-AIR SHIELD	30. SCREEN-PUMP NOZZLE SCREW
2. AIR SHIELD	31. GASKET-NOZZLE SCREW
3. SCREW (3)-CHOKE COVER CLAMP	32. VENTURI CLUSTER ASSY.
4. CLAMP-CHOKE COVER	33. GASKET-VENTURI CLUSTER
5. CHOKE COVER & SPRING ASSY.	34. WEIGHT-PUMP DISC BALL
6. GASKET-CHOKE COVER	35. BALL-PUMP DISC.
7. RETAINER-CHOKE ROD	36. SCREW (3)-PUMP VALVE
8. RETAINER-FAST IDLE CAM ROD (LOWER)	37. PUMP RELIEF VALVE ASSY.
9. RETAINER-CHOKE PULLDOWN ROD	38. GASKET-PUMP VALVE
10. SCREW & LKWSHR. (3)-CHOKE HOUSING	39. SCREW-THROTTLE KICKER
11. CHOKE HOUSING ASSY.	40. THROTTLE KICKER ASSY.
12. GASKET-CHOKE HOUSING	41. SCREW (4)-PUMP DIAPHRAGM COVER
13. SCREW (2)-CHOKE PULLDOWN ASSY.	42. COVER & LEVER ASSY. PUMP
14. CHOKE PULLDOWN MOTOR & HOSE ASSY.	43. PLUNGER-PUMP DIAPHRAGM
15. SCREW & LKWSHR. (3)-FEEDBACK CONTROL	44. PUMP DIAPHRAGM ASSY.
16. FEEDBACK CONTROL ASSY.	45. SPRING-PUMP DIAPHRAGM RETURN
17. GASKET-FEEDBACK CONTROL	46. PUMP ROD ASSY.
18. SCREW & LKWSHR. (6)-BOWL COVER	47. VALVE-PUMP INLET CHECK
19. BOWL COVER ASSY.	48. CAP (2)-IDLE LIMITER
20. SEAL-CHOKE ROD	49. NEEDLE (2)-IDLE ADJUSTING
21. GASKET-BOWL COVER	50. SPRING (2)-IDLE ADJ. NEEDLE
22. RETAINER-FLOAT PIN	51. NEEDLE PLUG (2)-IDLE LIMITER
23. FLOAT & LEVER ASSY.	52. SCREW & LKWSHR. (4)-ENRICHMENT VALVE COVER
24. PIN-FLOAT LEVER	53. COVER-ENRICHMENT VALVE
25. NEEDLE & SEAT, BAFFLE ASSY.	54. GASKET-VALVE COVER
26. SCREEN-NEEDLE SEAT	55. VALVE-ENRICHMENT (2 STAGE)
27. JET (2)-MAIN METERING	56. GASKET-ENRICHMENT VALVE
28. SCREW-CLUSTER	57. NUT & LKWSHR.-LEVER
29. SCREW-PUMP DISCHARGE NOZZLE	58. FAST IDLE LEVER & SCREW
	59. SCREW & WASHER (2)-SENSOR
	60. THROTTLE POSITION SENSOR
	61. MAIN BODY ASSY.

CLEANING

CLEANING MUST BE DONE WITH CARBURETOR DISASSEMBLED. SOAK PARTS LONG ENOUGH TO SOFTEN AND REMOVE ALL FOREIGN MATERIAL. USE A CARBURETOR CLEANING SOLVENT. MAKE CERTAIN THE THROTTLE BODY IS FREE OF ALL CARBON DEPOSITS. RINSE OFF IN SUITABLE SOLVENT. BLOW OUT ALL PASSAGES IN CASTINGS WITH COMPRESSED AIR AND CHECK CAREFULLY TO INSURE THOROUGH CLEANING OF OBSCURE AREAS. CAUTION: DO NOT SOAK PARTS CONTAINING RUBBER MATERIALS OR PARTS SUCH AS (5), (14), (16), (23), (37), (40), (44), (55), AND (60) IN CLEANING SOLVENTS.

REASSEMBLY

REASSEMBLE IN REVERSE ORDER OF DISASSEMBLY. NOTE SPECIAL INSTRUCTIONS AND FOLLOW NUMERICAL OUTLINE IN MAKING ADJUSTMENTS NECESSARY FOR CARBURETOR BEING SERVICED. DO NOT TIGHTEN BREAK-AWAY SCREWS UNTIL THE ADJUSTMENTS ON PAGE 3 ARE COMPLETED.

SPECIAL INSTRUCTIONS

ENRICHMENT VALVE (55)-USE CARE WHEN TIGHTENING TO PREVENT DISTORTION OF GASKET (56).

IDLE ADJUSTING NEEDLES (49)-TURN IN UNTIL LIGHTLY SEATED. THEN BACK OUT NUMBER OF TURNS RECORDED ON DISASSEMBLY. (DO NOT INSTALL CAPS (49) AT THIS TIME.)

PUMP INLET CHECK VALVE INSTALLATION (47)-LUBRICATE TIP OF NEW VALVE AND INSERT IN CENTER HOLE OF PUMP CAVITY. USE A NEEDLE NOSE PLIERS AND PULL THROUGH FROM FUEL BOWL SIDE UNTIL FULLY SEATED. CUT OFF VALVE TIP AT RETAINING SHOULDER.

PUMP DIAPHRAGM RETURN SPRING INSTALLATION (45)-INSTALL LARGE OPEN END OF SPRING OVER RUBBER INLET CHECK VALVE (47).

BOWL COVER GASKET (21) MAY OR MAY NOT BE OF THE CONFIGURATION SHOWN IN EXPLODED VIEW. USE THE KIT GASKET (ONE OF THREE) THAT MATCHES THE GASKET REMOVED FROM CARBURETOR EXCEPT FOR 5.8L CARBURETORS #E4TE-9510-ACA, ADA, AND E5TE-9510-PA, AAA. USE THE GASKET STAMPED "E3TE-9581-BA".

ADJUSTMENTS

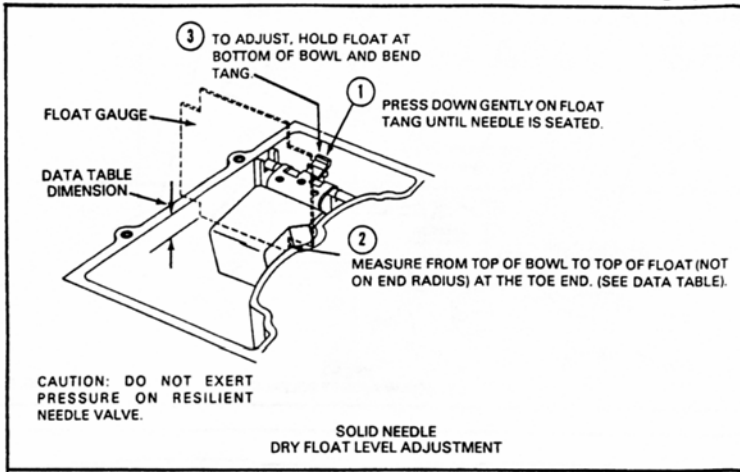

**SOLID NEEDLE
ADJUSTMENT DATA TABLE**

YEAR	APPLICATION	DRY FLOAT LEVEL	WET FUEL LEVEL
1982-83, 85	PASSENGER CAR 3.8L, 4.2L, 5.0L ENG.	7/16"	.810"
1982-83	LIGHT TRUCK-RANGER, BRONCO II 3.8L, 4.2L, 5.0L ENG. 5.0L ENG. CARB. NOS. E2TE-BPA, BRA, E2UE-JA, E3TE-AZA, BAA 5.8L, 6.6L ENG.	3/16"	.810"
1983-86	LIGHT TRUCK-RANGER, BRONCO II, AEROSTAR 2.8L ENG.	7/16"	.810"
1984-85	LIGHT TRUCK-RANGER, BRONCO II 5.0L ENG. 5.8L ENG.	9/32"	.875"
		1/4"	.810"

THE INFORMATION AND SPECIFICATIONS CONTAINED HEREIN ARE BASED ON LATEST PRODUCT INFORMATION AVAILABLE AT THE TIME OF PUBLICATION. THE RIGHT IS RESERVED TO MAKE CHANGES AT ANY TIME WITHOUT NOTICE.

PLEASE REFER TO THE ENGINE DECAL, SERVICE SPECIFICATIONS, AND TECHNICAL BULLETINS FOR REVISIONS TO THIS INFORMATION.

FIG. 1

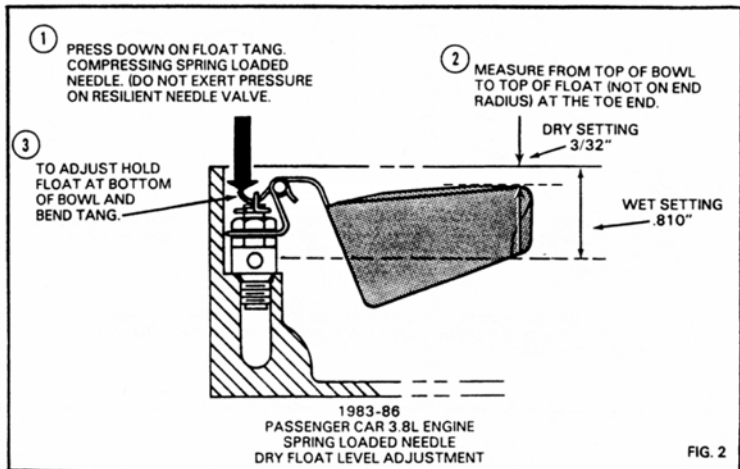

FIG. 2

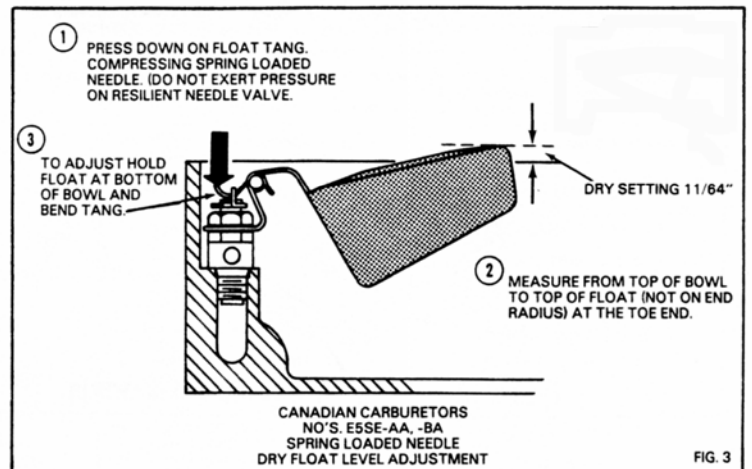

FIG. 3

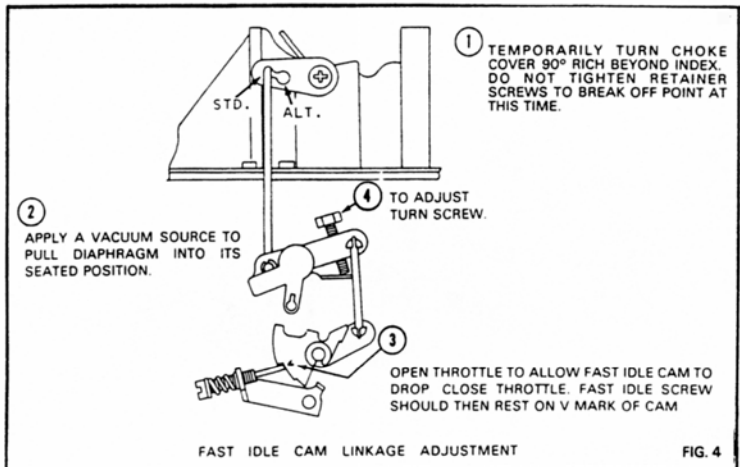

FIG. 4

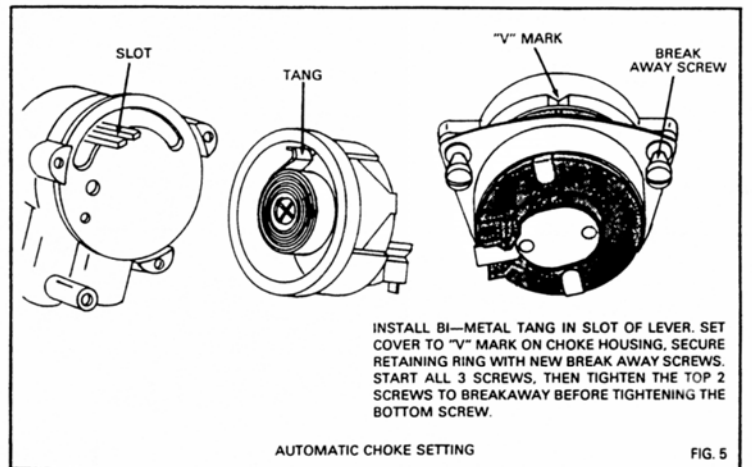

FIG. 5

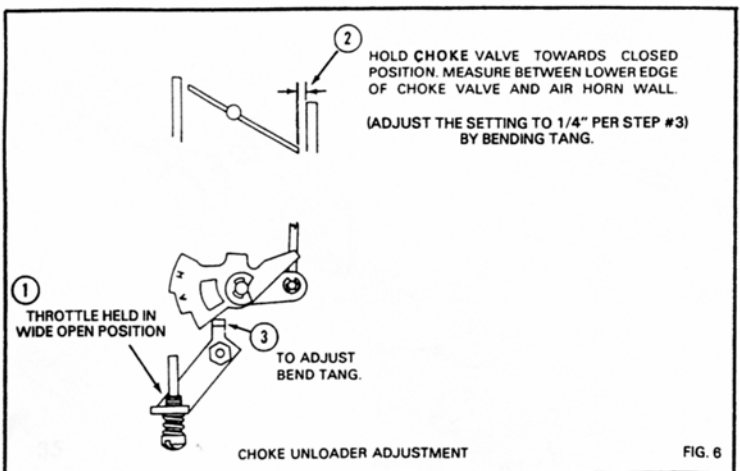

FIG. 6

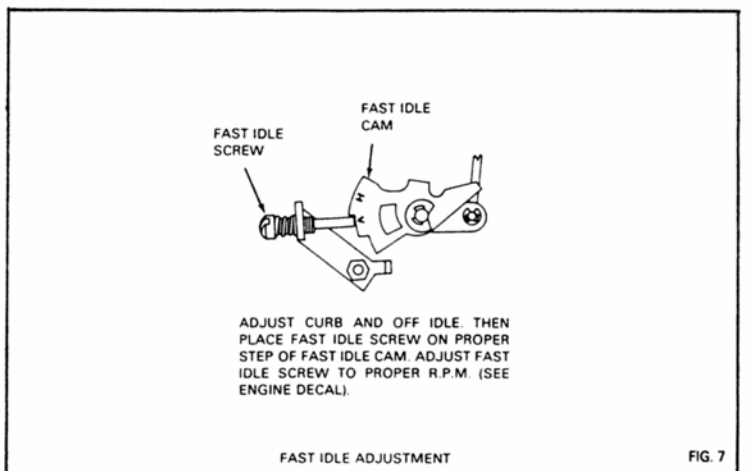
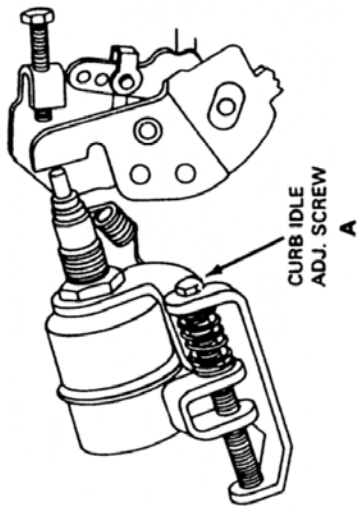

FIG. 7

USE FACTORY CAR MANUAL PROCEDURE FOR SETTING SLOW (CURB IDLE). (SPECIFICATIONS LISTED ON ENGINE DECAL.) INSTALL CAPS AFTER SETTING IDLE MIXTURE.



CURB IDLE ADJ. SCREW
A

TYPE A
BRACKET ADJUST SOLENOID

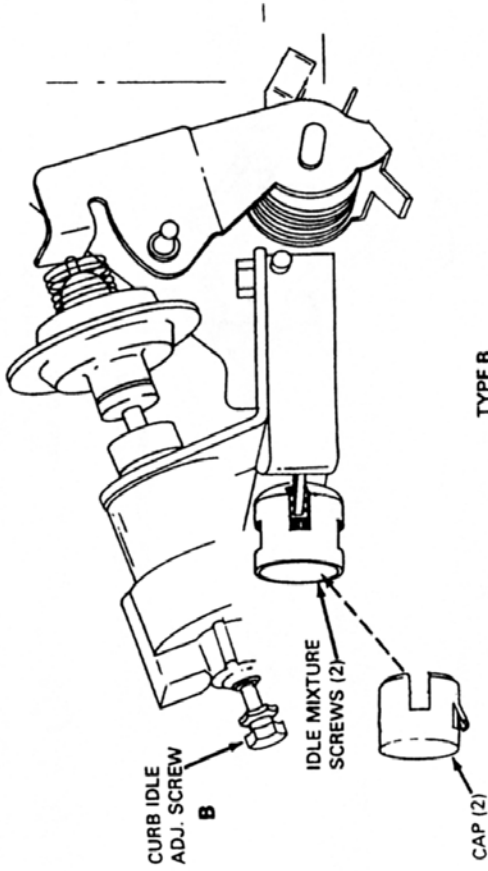

CURB IDLE ADJ. SCREW
B

IDLE MIXTURE SCREWS (2)
C

CAP (2)
D

TYPE B
END SCREW ADJUST SOLENOID

FIG. 8

PHENOLIC SPACER SERVICE

REMOVE PHENOLIC SPACER. INSPECT GASKET SURFACES. IF GASKET MATERIAL HAS NOT BEEN DAMAGED USE SPACER AS IS AND INSTALL NEW GASKETS ON BOTH SIDES OF SPACER.

IF GASKET MATERIAL IS TORN, SCRAPE OFF OLD MATERIAL AND INSTALL NEW GASKETS ON BOTH SIDES OF SPACER.

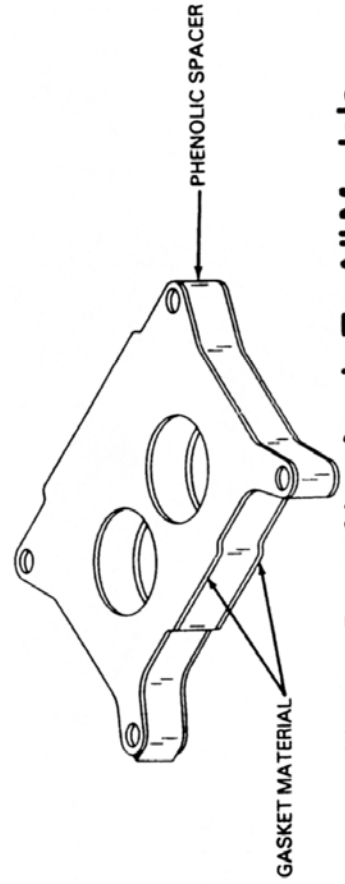

GASKET MATERIAL

PHENOLIC SPACER

Note: Does Not Apply To All Models.

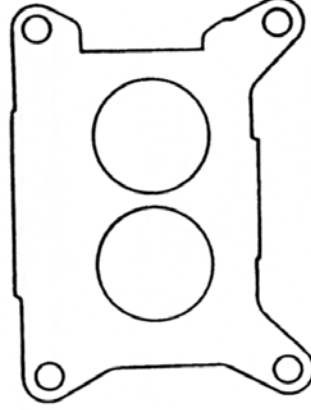

USE THIS GASKET WITH CARBURETORS THAT ARE EQUIPPED WITH THROTTLE POSITION SENSOR MOUNTED ON THE THROTTLE BODY.

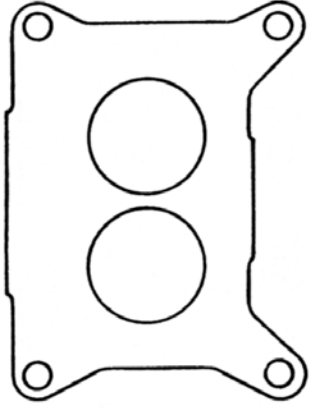

USE THIS GASKET WITH CARBURETORS NOT EQUIPPED WITH THROTTLE POSITION SENSOR.

CAUTION: MATCH GASKETS TO CONFIGURATION OF PHENOLIC SPACER UNDER CARBURETOR. USE OF INCORRECT GASKETS COULD CAUSE A VACUUM LEAK AT CARBURETOR BASE.

FIG. 9