

Steeroids™ INSTALLATION INSTRUCTIONS

1967-1969 Camaro, 1968-1974 Nova

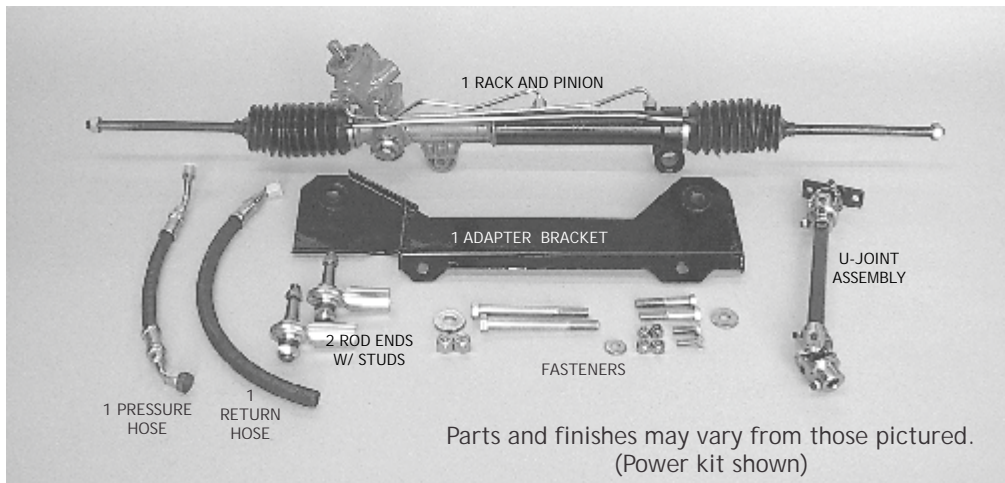

Verify Kit Contents:

- 1 RACK AND PINION
- 2 ROD ENDS
- 1 U-JOINT ASSEMBLY
- 1 ADAPTER BRACKET
- 2 ½- 13 x 5 GRADE 8 BOLTS
- 2 ½- 13 ELASTIC NUTS
- 2 ½ WASHERS
- 2 7/16-14 x 2.5 GRADE 8 BOLTS
- 2 7/16-14 ELASTIC NUTS
- 2 7/16 WASHER
- 1 5/16-24 x 1 GRADE 8 BOLT
- 1 5/16-24 ELASTIC NUT
- 1 3/8-24 X 1 GRADE 8 BOLT
- 1 3/8-24 ELASTIC NUT
- 2 M14 X 1.5 JAM NUTS

Power Kit Only:

- 2 PUMP HOSES (1 PRESSURE, 1 RETURN)

PLEASE NOTE: These components are tested and engineered to meet loads equal to what the stock steering system is exposed to during normal operation. If you or the person or firm you hire to install your Steeroids rack & pinion kit believes it is necessary to "modify" any components to make them fit and /or adjust properly PLEASE note that this is extremely dangerous. We offer free technical phone support to assist with installation should you encounter a problem. Modifications may include cutting or welding support brackets, sawing or hammering on u-joints, or any revision, deletion or addition to the product as delivered, and should NEVER be required. Any such modifications void the manufacturers warranty. Our knowledgeable staff will gladly assist you with any questions you may have during installation. In addition Class M Corporation, DBA SpeedDirect is not responsible or liable for any damages or injury resulting from any modification to the components as delivered.

We are constantly updating our instructions, check for the latest version at <http://speeddirect.com/index.aspx?nodeID=79>

BEFORE BEGINNING: Please note each steering rack is bench tested prior to shipping therefore some of the fluid from the test occasionally leaks out and may stain the box. This does not mean the rack has been damaged if fluid has leaked out.

You may also find two small rubber o-rings attached to your rack with a twist tie, these are merely extras that are sometimes supplied with our steering racks. The power steering hose adapters supplied with your kit should already have o-rings attached, so the extras can be discarded.

1. Begin by performing an inventory of all the components in the kit. Installing the Steeroids kit requires simple hand tools. A pickle fork will be useful when disassembling the old tie rod ends.

2. Begin by supporting the car securely on jack stands. Never support the car using only a jack.

3. Removing the entire steering system as a unit is the most effective way. The outer tie rods require removal of a cotter pin and nut before separating from the steering knuckle using a pickle fork. Once both tie rods are separated from their respective steering knuckles, remove the two bolts attaching the steering column to the steering box. The steering box is attached with 3 bolts that extend through the frame from the driver's side wheel well. Remove two of the bolts. Leave the last bolt installed until you are ready to remove the entire system.

4. Now remove the two bolts and nuts that attach the idler arm to the passenger side frame rail. The final bolt holding the steering box can be removed now, but **BE PREPARED TO SUPPORT THE STEERING BOX WHEN IT COMES LOOSE**. Lower the steering system out of the car. You might have to work the bolts and rag joint loose from the steering column. If your headers interfere with removing the steering box you can loosen the bolts at the cylinder head flange. This will allow the headers to swing out of the way to remove the box, yet you can re-tighten the bolts without having to replace the gasket.

ASSEMBLY AND INSTALLATION

We recommend using red high strength thread lock on all threaded applications except for power steering hose fittings and tie rod sleeves. Be SURE to trial fit first, and read the instructions through before going crazy with the thread lock!

5. Thread each tie rod onto the steering rack an equal amount. To set an approximate alignment, measure the overall length of the old steering system. Measure from the center of each outer tie rod. Adjust the tie rods on the steering rack to match your

measurement and tighten the jam nuts against the rod ends. Using an adjustable wrench, turn the pinion until the rack is at its stop. Now count the turns as you proceed to the opposite stop. Divide the number you get by 2 and turn the pinion this amount. The steering rack is now centered.

6. The adapter bracket attaches to the frame at the aft, lower a-arm mount. The existing bolts must be removed. Installing the new bolts while the old bolts are still half way in will help keep the bushing aligned with the hole. Install the first bolt with washer, through the bracket then about one inch into the bushing. Push the bracket until it contacts the frame and install the second bolt. Completely install both bolts and nuts. Torque to 80 ft-lbs. NOTE: If the bolts are installed with the ends pointing towards the back of the car, it will be easier to remove the bracket if needed. This can increase the difficulty of the initial installation but will be worth the time invested. Be sure to use a washer on the bracket side of the bolt.

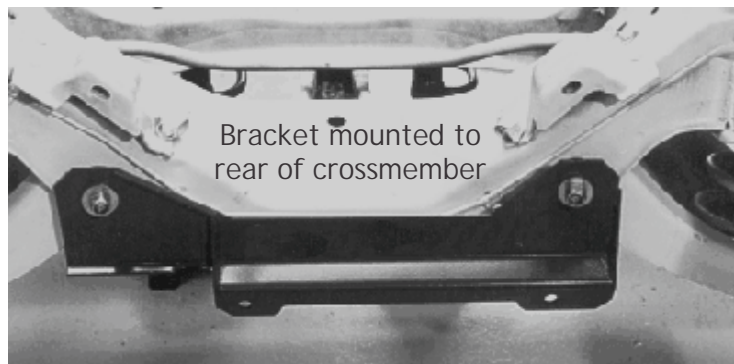

7. Install the U-joint assembly on the steering rack. See diagram below on u-joint orientation. Use a high strength thread locker on the setscrews.

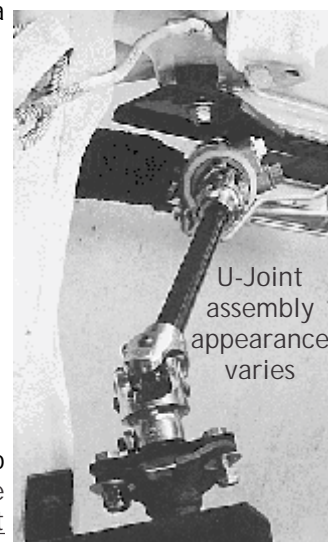
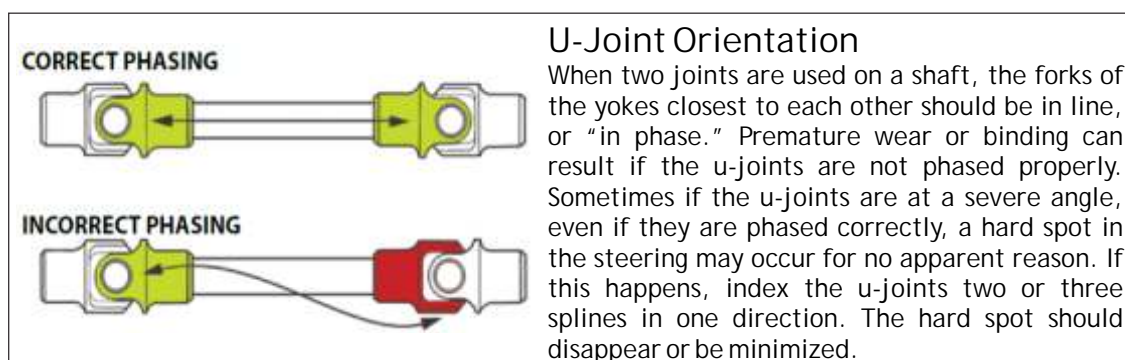

Now install the rack and pinion on the bracket using the supplied bolts, washers and nuts. Torque to 59 ft-lbs. Now proceed to attach the outer tie rod ends to the steering arms (spindles). Before torquing, read the following details. NOTE: the flange below the taper may not seat against the steering arm- this is not a problem. If your car has two holes in the steering arm install the tie rod end in the hole closest to the front of the car. Using the hole towards the rear will increase the steering radius. To properly adjust the outer tie rods, use the included bump steer spacers. Start with half above and half below the tie rod end bearing. As needed, move the spacers above or below the bearing so that the entire length of the tie rod matches the angle of the lower control arm with the vehicle on the ground and the suspension settled (the tie rod sleeve should be as close to parallel with the lower control arm pivot points as possible - not necessarily the ground). You may need to come back and adjust this once installation is complete, especially if no engine is installed. Torque nylock/castle nut (whichever was supplied) to 35 ft-lbs. [If you have castle nuts: Continue to tighten the nut to align castellation with the cotter pin hole. Install cotter pin.] When attaching the tie rod end to the spindle, torque the 15/16" nylock nut to 50 ft lbs. (Note: the flange above the taper may not seat against the spindle - this is not a problem.)

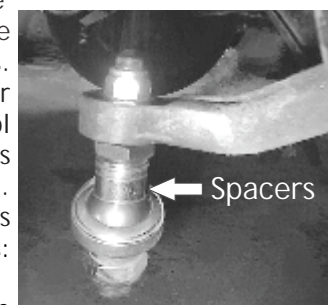

8. Now bolt the other end of the U-joint assembly to the steering column. (See picture on right) Turn the column/steering wheel to align the holes. You will most likely have to re-center the steering wheel by removing it from the column, centering and reinstalling.

9. The steering shaft should be able to be turned by hand (with the wheels off the ground). If you experience binding in the u-joint assembly, the steering column should be moved towards the rear of the car. Adjust the column by loosening the nuts under the dash and pulling it back. You may also need to move the end of the column toward the engine to eliminate binding.

Note: If you are installing a manual kit, skip to step 12

10. Next, attach the power steering hoses. The large hose fitting on the rack is the pressure side. (See picture at right) This connects to the threaded fitting on your pump. Tighten to 21 ft-lbs. The return side is torqued to 13 ft-lbs.

It is very important to connect these hoses to their proper locations. Reversing the hoses will destroy seals and cause the rack to operate inconsistently and uncontrollably. Power steering fluid recommendations: Run standard GM Power Steering Fluid. For those

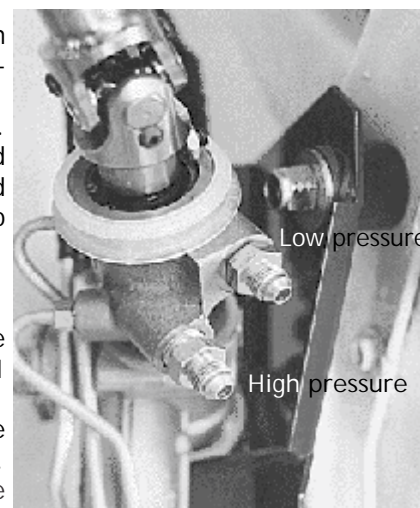

who prefer synthetic fluids you may switch to Royal Purple Synthetic after 1000 miles, but it is not required.

11. Bleed the system by turning the wheels all the way to the left. Add fluid to the "cold" mark on the dipstick. Turn the wheel back and forth 3 or 4 times. Start the car and allow it to idle. Fill to the "cold" mark as needed. (A) Now turn the wheels side to side until there are no more bubbles. Check the fluid level frequently while proceeding. Allow the engine to run for a few minutes. Add fluid as needed. Replace cap and shut off engine. If the fluid level rises after the engine is shut off, there is still air in the system. Repeat (A) until all air is out of the system. "Flushing" the system is not necessary, you are only bleeding it of air.

12. Now re-check every bolt and nut to be sure all are tight. Briefly test-drive the car at low speed. Check every bolt for tightness again. If the engine is at operating temperature, check the power steering fluid level. Fill to the "hot" mark as needed.

13. The final step is to have the front end aligned to the specs below and re-check all bolts for tightness after the first 100 miles. If the person installing the kit ignores these recommendations and it is aligned to factory specs, the car will handle very poorly. This is VERY important.

Alignment recommendations for spirited driving:

<u>Camber</u>	<u>Caster</u>	<u>Toe</u>
0 - .25 negative camber	2.5 - 5 positive	0 to 1/8" toe in

CAUTION: The steering ratio of this kit is significantly faster than the stock steering. Exercise caution when first driving with the new system. The vehicle will respond quicker and turn more from the same amount of steering input. This might take some time to get used to.

STEEROIDS WARRANTY

All Steeroids Rack & Pinion Conversion Kits (the Kit) purchased from Class M Corporation, DBA SpeedDirect, hereafter SpeedDirect or an authorized reseller are warranted, subject to limitations and exceptions defined herein, against defects in materials and workmanship for a period of five years from the date of shipment from the SpeedDirect warehouse. During this five-year period, SpeedDirect will repair or replace any covered component found to be defective at no charge to the purchaser except freight costs which will be assessed for any claim made after 30 days from to original purchase date. All claims shall be sent to and from the nearest SpeedDirect office. Any and all costs for inspection, removal or replacement of the Kit or its constituent parts or assemblies under this warranty are the responsibility of the original purchaser.

This warranty does not apply to equipment which in the judgment of SpeedDirect was used in racing or has been subjected to misuse, accidental or intentional damage, or has been installed in a manner or under conditions other than those expected in a normal driving. This warranty is also void if the equipment has been modified (unless such modification has been expressly approved in writing by SpeedDirect).

Warranty applies only to the original purchaser. Purchaser is responsible for retaining the original Sales Invoice for the Kit as proof of purchase which shall be presented to SpeedDirect in order to receive any consideration of repair or replacement as defined within this warranty.

Exceptions & limitations to this warranty are: SpeedDirect may, at its sole discretion, extend warranty coverage on any product or assembly item beyond these stated limits on a case-by-case basis. This warranty is in lieu of all others expressed or implied, and no representative or person other than a corporate officer of Class M Corporation is authorized to assume any liability other than that expressed herein on behalf of Class M Corporation, DBA SpeedDirect.

SpeedDirect accepts no liability for loss of service, loss of revenue, or any special or consequential damages that may arise from the failure or malfunctions of its products. Defective products or components shall only be returned to the SpeedDirect repair facility after receiving a written Return Authorization and shipping instructions.

STEEROIDS REPLACEMENT POLICY

Labor charges and/or damage incurred in installation, repair or replacement as well as incidental and consequential damages connected therewith are excluded and will not be paid by seller. Any and all costs for inspection, removal or replacement of the kit or its constituent parts or assemblies under this warranty are the responsibility of the original purchaser.



SpeedDirect
1901 S. FM 129, Santo, TX 76472, Tech Line (970) 731-1381 dept. 2
www.speeddirect.com



PRODUCT EVALUATION SHEET

Telling us what you like and don't like determines what we make and how we make it. We would appreciate it if you would take just a few minutes of your time to answer the following questions about the parts you ordered from us. Simply fold this form on the dotted lines, seal with tape and mail it to us. *Do not use staples and make sure our address faces out.* SpeedDirect will not disclose the information it collects to outside parties. SpeedDirect does not sell, trade or rent your personal information to others. Your privacy is important to us.

1) Kit: Camaro Steroids

2) Where did you learn about this kit?

- Magazine Ad Friend
- Internet Search Forum
- Mechanic Catalog
- Car Show
- Other (specify) _____

3) What influenced you the most to buy this kit?

- Magazine Ad Price
- Recommendation Testimonials
- Internet Forum
- Other (specify) _____

4) Did you have any trouble understanding the written instructions? If yes, please explain.

- Yes No

5) Did you have any trouble understanding any of the photographs? If yes, please explain.

- Yes No

6) Was any of the installation difficult for you? If yes, please explain.

- Yes No

7) Were any of the kit parts:

- Damaged Missing

If you checked any of the above boxes, did you contact our customer service department to resolve the problem?

- Yes No

8) Were they helpful in resolving the problem?

- Yes No

9) What did you like most about this kit?

- Instructions Hardware Supplied
- Ease of Install Price
- Final Performance Other:

10) What did you like least about this kit?

- Instructions Hardware Supplied
- Ease of Install Price
- Final Performance Other:

11) Have you driven/used the product and are you satisfied with the final installation?

Please explain:

- Yes No

12) What is your age group?

- 18-29 30-39 40-49
- 50-59 60-69 70+

We care about what you think. Is there anything else you would like to tell us or any products you would like to see us make in the future?

Fold here

Fold here

PLACE
STAMP
HERE

Speed Direct
1901 S FM 129
Santo TX 76472