



21730 Hanover Ave Lakeville, MN 55044

INSTALLATION INSTRUCTIONS

1979-1993 MUSTANG CASTER/CAMBER PLATES

READ ALL OF THE INSTRUCTIONS BEFORE YOU BEGIN THIS PROJECT

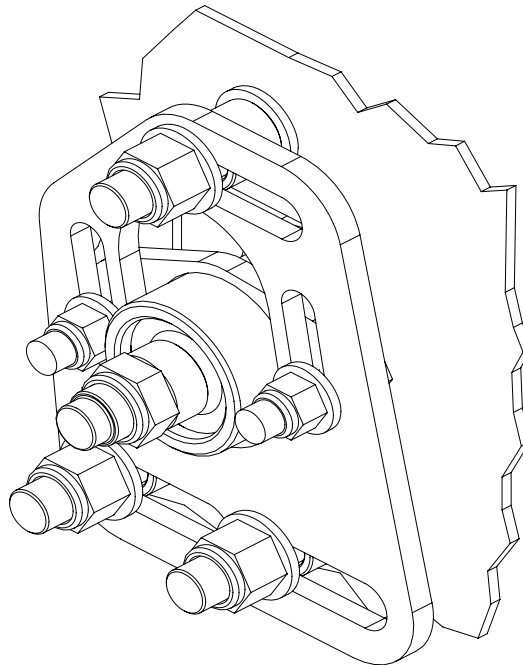

DISCLAIMER/WARRANTY

SELLER DISCLAIMS ANY WARRANTY, EXPRESSED OR IMPLIED, WITH RESPECT TO THE PARTS SOLD HEREBY AS TO MERCHANTABILITY, FITNESS FOR PARTICULAR PURPOSE, OR ANY OTHER MATTER. PRODUCTS MANUFACTURED BY QA1 MOTORSPORTS, AND/OR CONTAINED HERE ARE DESIGNED FOR COMPETITION PURPOSES. ACCORDINGLY, USE OF SAID PRODUCTS, OR MODIFICATION TO OR CONSTRUCTION OF A VEHICLE FOR THOSE PURPOSES MAY CREATE DANGEROUS CONDITIONS, WHICH COULD CAUSE BODILY INJURY, AND THE BUYER HEREBY ASSUMES ALL RISKS ASSOCIATED WITH ANY SAID PRODUCTS.

READ ALL OF THE INSTRUCTIONS BEFORE YOU BEGIN THIS PROJECT

1. Jack up the front of the vehicle and place jack stands securely on the frame of the car.
2. Remove front wheels.
3. Place a floor jack under the control arm and jack up until slightly loaded.
4. Remove the strut shaft top mounting nut.
5. Remove the three nuts that hold the factory upper strut mounting plate in place and remove it from the car.
6. Carefully lower the jack to bring the strut shaft down through the strut tower center hole, but do not completely un load the jack: the spring may become dislodged and fly out, causing injury and/ or damage to the vehicle.
7. Remove all washers, collars, bushings, etc, from the strut shaft.
8. Collapse the strut shaft down into the strut body far enough to remove the factory bottom plate, and dust boot.
9. Remove the factory dust boot and discard. Leave the factory bumpstop on the strut shaft.
10. Install the bottom plate beneath the strut tower with the bolts protruding upwards through the factory mounting slots and hole. (See illustration #1) Make sure the bottom plate bolts move freely in the adjusting slots of the strut tower. If not, file the slots until they do.
11. Pull the strut shaft up out of the strut body and carefully jack up the control arm until the strut shaft is back in position, protruding through the large center hole.
12. Install a 14mm washer over each bolt of the bottom plate. These washers will rest directly on top of the car's strut tower. (See illustration #1)
13. Install a 14mm ID spacer over each bolt of the bottom plate. (See illustration #1)
14. Check illustration #2 to identify the driver's side and passenger's side top plates. Verify that the bearing housing assembly is positioned with the bearing offset to the rear of the car.
15. Install the appropriate top plate with the bearing housing assy mounted to its underside. The large center slot will be biased towards the rear of the car (for increased positive caster adjustment).
16. Install the washers and the locking nuts on the bolts of the bottom plate.
17. The strut shaft is installed through the spherical bearing with three of the 16mm ID spacers. The various strut manufacturers each have their unique length for the top

threaded portion of the strut shaft. You must determine the proper combination of spacers to put above and below the bearing for your struts. You will probably have spacers both above and below the bearing. You want to position the strut shaft just low enough that it will not hit the underside of the hood. Suggestion: Before dismantling anything on your car, lay a straight edge across the top of the fenders and measure down to the top of the strut shaft. Try to match that dimension when you install the strut with the spacers.

18. Reinstall the strut shaft top mounting nuts.
19. Temporarily tighten the caster/camber plate adjusting nuts: the two lock nuts for caster and the three for camber.
20. Pull the bumpstop down slightly until after the alignment is completed. Then push it up until it contacts the bottom of the bearing plate.
21. Reinstall wheels and carefully lower the vehicle to the ground.
22. Remember to torque the lug nuts to Ford's specs.
23. Have your car professionally aligned.
24. When the alignment is complete, torque the caster/camber plate adjusting nuts:

Two caster nuts	40 ft/lbs
-----------------	-----------

Three camber nuts	65 ft/lbs
-------------------	-----------

Note: Because camber and caster can be adjusted independently, you can adjust one, lock it down, and then adjust the other. Always double-check all camber and caster measurements after any adjustment of even one parameter.

The camber adjustment slots when used in conjunction with the factory camber adjustment slots, allow the widest range of camber adjustment possible.

If you are adjusting towards the extreme limits of camber and/ or caster, be sure to double check the clearance between the strut shaft and the edge of the large center hole of the strut tower. Check not only with the wheels pointed straight ahead, but also while turning the steering wheel lock to lock. In some instances, Ford's production tolerances on the positioning of that center hole can cause interference when camber or caster is adjusted towards the limit of travel.

Remember that any time you make any change in camber, caster, or ride height, you must readjust the toe setting.

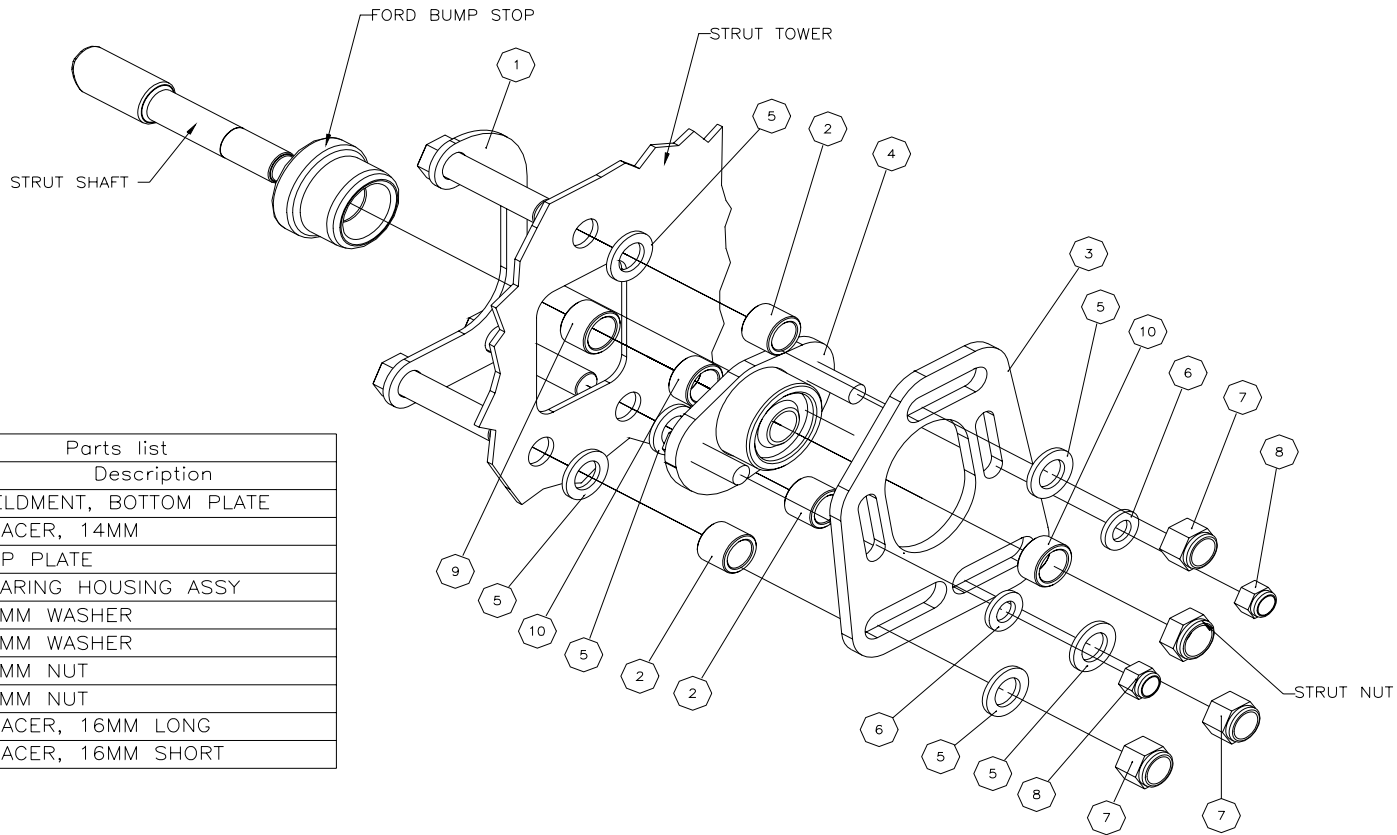

Parts list	
Item	Description
1	WELDMENT, BOTTOM PLATE
2	SPACER, 14MM
3	TOP PLATE
4	BEARING HOUSING ASSY
5	14MM WASHER
6	10MM WASHER
7	14MM NUT
8	10MM NUT
9	SPACER, 16MM LONG
10	SPACER, 16MM SHORT

Illustration 1

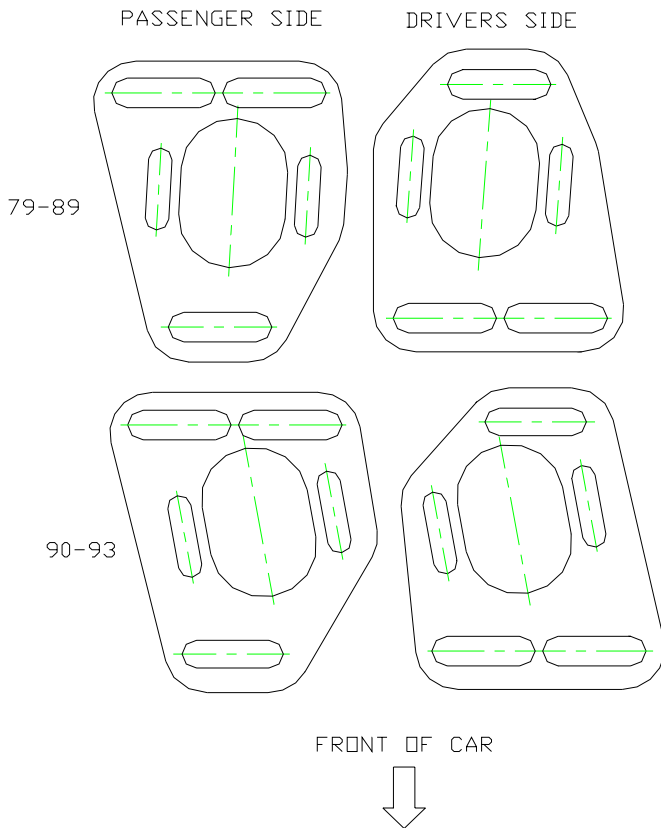

Illustration 2